

ITEM NO.	PART NUMBER	QTY.	PRICE
1	400-016 Base Block	1	
2	400-012 Bushing Block	1	
3	HX-SHCS 0.3125-18x1x1-N	12	
6	DPM 0.3125x1	2	
6	400-013-01	1	
7	400-013-01	1	

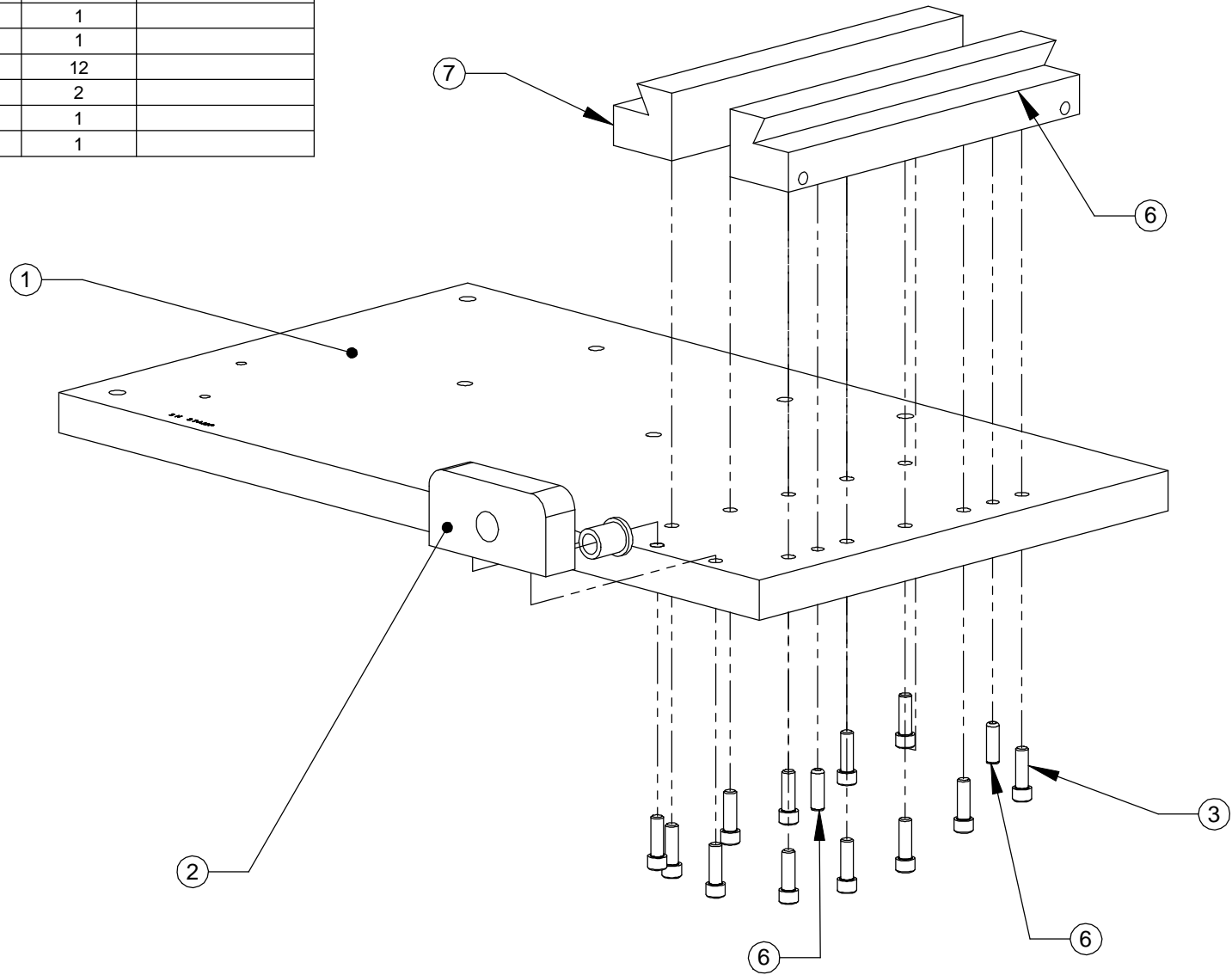

PROPRIETARY AND CONFIDENTIAL
 THE INFORMATION CONTAINED IN THIS DRAWING IS THE SOLE PROPERTY OF MITTLER BROS. MACHINE & TOOL. ANY REPRODUCTION IN PART OR AS A WHOLE WITHOUT THE WRITTEN PERMISSION OF MITTLER BROS. MACHINE & TOOL IS PROHIBITED.

		UNLESS OTHERWISE SPECIFIED:		NAME	DATE
		DIMENSIONS ARE IN INCHES		DRAWN	RAJ 06/25/08
		TOLERANCES:		CHECKED	
		FRACTIONAL ±.015		ENG APPR.	
		ONE PLACE DECIMAL ±.015		MFG APPR.	
		TWO PLACE DECIMAL ±.010		Q.A.	
		THREE PLACE DECIMAL ±.005		COMMENTS	
		ANGULAR ±1°			
		QUANTITY			
		MATERIAL			
		FINISH			
NEXT ASSY	USED ON				
APPLICATION		DO NOT SCALE DRAWING			

MB MITTLER BROS. MACHINE & TOOL

10 Cooperative Way, Wright City, MO. 63390
 (636)745-7757 Fax (636)745-2874

TITLE: Base Assembly		
SIZE A	DWG. NO. 400-A01-E	REV
SCALE: 1:8	WEIGHT:	SHEET 1 OF 1