

560 POWER SHRINKER/STRETCHER EXPLODED ASSEMBLY

REV 10/15/09
REV 11/15/11
REV 4/29/20

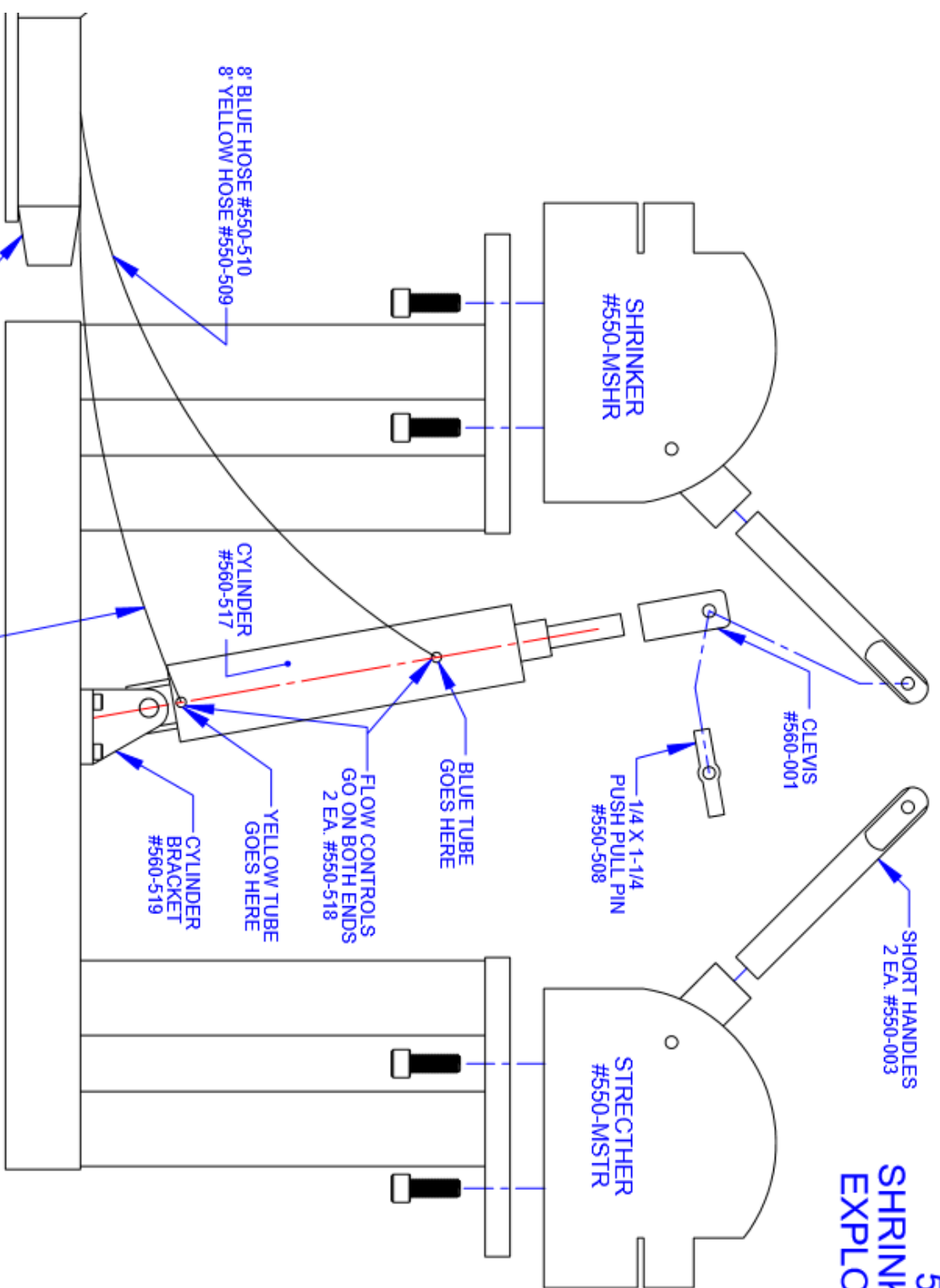

CONTENTS INCLUDE:
QTY. DESCRIPTION:

- 4 3/8" X 1" BOLTS TO MOUNT UNITS
- 2 #550-518 FLOW CONTROLS FOR CYLINDERS
- 2 #550-003 SHORT HANDLES
- 1 #360-001 CLEVIS
- 1 #550-508 1/4" PUSH PULL PIN
- 1 #550-505 FOOT VALVE
- 1 #550-005 FOOT PLATE
- 2 #550-506 AIR FITTING
- 2 #350-501 MUFFLER
- 8' #550-509 YELLOW 1/4" TUBE
- 8' #550-510 BLUE 1/4" TUBE
- 5 #550-507 PLASTIC HOSE CLIPS
- 1 #560-517 CYLINDER
- 1 #560-519 CYLINDER BRACKET
- 1 #560-A01 FRAME ASSEMBLY

- FOOT PEDAL ASSEMBLY
- 1 EA. #550-005 FOOT PLATE
- 1 EA. #550-505 VALVE
- 2 EA. #350-501 MUFFLER
- 2 EA. #550-506 AIR FITTING
- 2 EA. 1/4" X 1-1/4 SHCS
- 2 EA. 1/4" FLAT WASHER
- 5 EA. HOSE CLIPS #550-507



10 COOPERATIVE WAY
WRIGHT CITY, MO 63390
(636) 745-7757

PART#	QTY.	PART DESCRIPTION
9-1	1	BODY
9-2	1	PRESSURE ARM
9-3	1	FULCRUM ARM
9-4	1	HANDLE WITH VINYL GRIP
9-5	1	PRESSURE ARM PIN
9-6	1	FULCRUM ARM PIN
9-9	2	LARGE JAW (SHRINKER) <i>Not Sold Separately. See Cartridge Kits Below</i>
9-10	2	SMALL JAW (SHRINKER) <i>Not Sold Separately. See Cartridge Kits Below</i>
9-11	1	SUSPENSION WIRE (SHRINKER) <i>Not Sold Separately. See Cartridge Kits Below</i>
9-12	1	UPPER PRESSURE V BLOCK (SHRINKER) <i>Not Sold Separately. See Cartridge Kits Below</i>
9-12A	1	LOWER PRESSURE V BLOCK (SHRINKER) <i>Not Sold Separately. See Cartridge Kits Below</i>
9-13	2	PRESSURE SPRING <i>Not Sold Separately. See Cartridge Kits Below</i>
9-14	1	VINYL GRIP FOR HANDLE
9-18	1	PRESSURE ARM RELEASE SPRING
9-27SH	1	COVER FOR SHRINKER <i>Not Sold Separately. See Cartridge Kits Below</i>
9-27ST	1	COVER FOR STRETCHER <i>Not Sold Separately. See Cartridge Kits Below</i>
9-28	4	SOCKET HEAD SCREW (8-32 x 318)
9-28W	4	EXT. TOOTH LOCK WASHER
9-38	2	MACHINE SCREW (8-32 X 318) <i>Not Sold Separately. See Cartridge Kits Below</i>
9-154	2	STRETCHER JAW (SPRING SLIDE) <i>Not Sold Separately. See Cartridge Kits Below</i>
9-155	2	STRETCHER JAW <i>Not Sold Separately. See Cartridge Kits Below</i>
9-156	1	UPPER PRESSURE BLOCK (STRETCHER) <i>Not Sold Separately. See Cartridge Kits Below</i>
9-156A	1	LOWER PRESSURE BLOCK (STRETCHER) <i>Not Sold Separately. See Cartridge Kits Below</i>
9-174	2	RIVET
9-175	1	SUSPENSION WIRE (STRETCHER) <i>Not Sold Separately. See Cartridge Kits Below</i>
9-176	2	MACHINE SCREW (8-32 x 1) <i>Not Sold Separately. See Cartridge Kits Below</i>

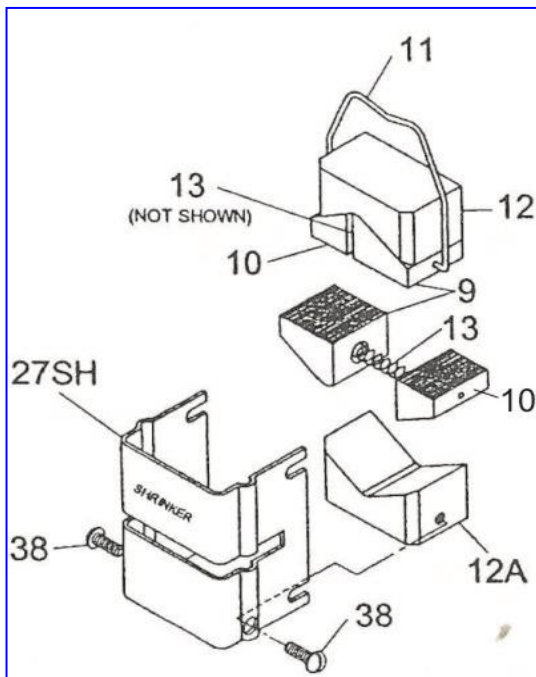

SHRINKER CARTRIDGE
COMPLETE
550-511

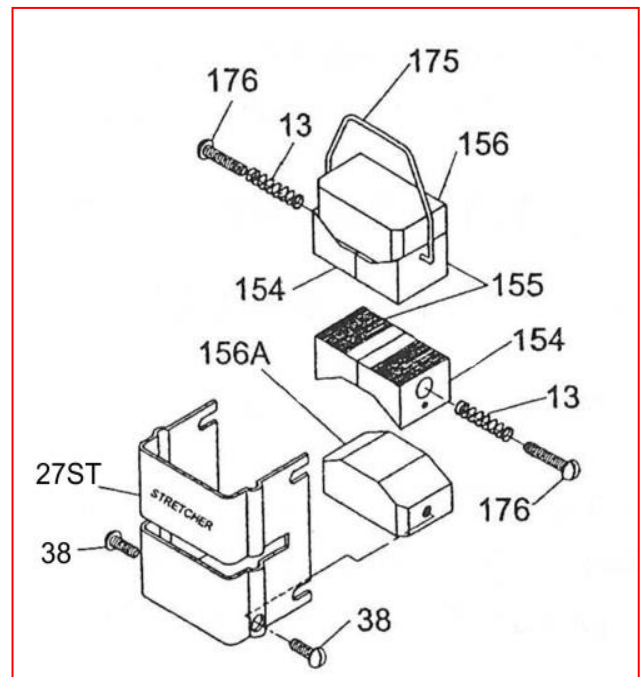

STRETCHER CARTRIDGE
COMPLETE
550-512

GENERAL MAINTENANCE

Before using your Shrinker or stretcher a small amount light weight grease as outlined below make your tool work smoother and prevent wear.

- Lubricate (light weight grease) the pivot point between the pressure arm (#2) and the fulcrum arm (#3).
- Lubricate (light weight grease) on Shrinker Upper & Lower Pressure V Block (#12 & 12A).
- Lubricate (light weight grease) on Stretcher Upper & lower Pressure Block (#156 & 156A).

Clean the jaws occasionally. Blowing them out with an air hose helps but it doesn't do the job thoroughly. Vacuuming helps to get filings out. The best way to maintain the jaws is to periodically disassemble them and clean as follows:

1. Remove Shrinker or Stretcher cartridge (cover/jaw assembly) by loosening four socket head screws.
2. Take out upper jaws and V blocks (Shrinker) or upper jaws and pressure block (Stretcher) as a single assembly. Be careful! DO NOT lose the spring between the jaws!
3. Remove suspension wire.
4. Take notice as to how the Shrinker jaws are inserted. A small jaw is opposite a larger jaw, top to bottom.
5. Clean the two upper jaws with a non-hazardous metal cleaner and a file card (brush). DO NOT use a wire brush or a wire wheel.
6. Always brush in the direction of the Teeth (with the grooves).
7. Clean the V block (Shrinker) or pressure block (Stretcher).
8. Re-assemble the upper jaws and set aside.
9. After removing the two machine screws at the lower end of the cover, remove the bottom jaws by lifting and taking out as a single unit with the V block (Shrinker) or pressure block (Stretcher). Clean all as described previously.
10. Replace jaws. Be careful to locate larger Shrinker jaw opposite small Shrinker jaw. When replacing the V blocks (Shrinker) or pressure blocks (Stretcher), chamfered corners face front.
11. Oil jaws lightly when not in use for extended periods.
12. For best operating results, clean the jaws after every job.

TROUBLESHOOTING

- Pull flow control cap (A) outward and turn clockwise (cw) until tight. Then turn counter-clockwise (ccw) 3 full turns.
- To increase flow turn ccw, to decrease flow turn cw.

