

DEGREE WHEEL RETROFIT KIT

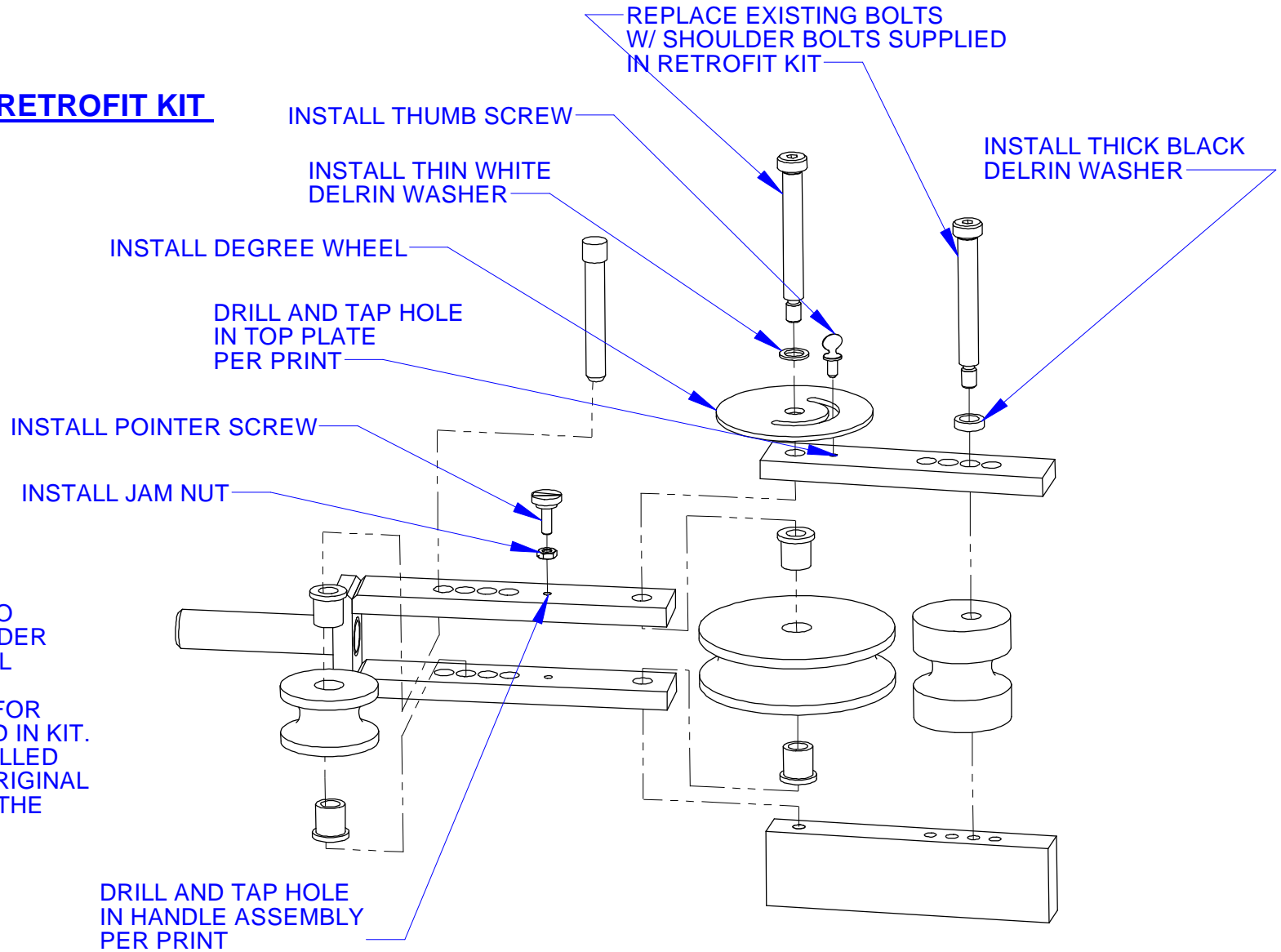

REQUIRED CHANGES TO EXISTING MANUAL BENDER TO ADD DEGREE WHEEL RETROFIT KIT. ALL REQUIRED PARTS FOR CHANGE ARE INCLUDED IN KIT. (2) HOLES MUST BE DRILLED AND TAPPED IN THE ORIGINAL PIECES TO COMPLETE THE ASSEMBLY.

DRILL AND TAP HOLE IN HANDLE ASSEMBLY PER PRINT

PROPRIETARY AND CONFIDENTIAL
THE INFORMATION CONTAINED IN THIS DRAWING IS THE SOLE PROPERTY OF MITTLER BROS. MACHINE & TOOL. ANY REPRODUCTION IN PART OR AS A WHOLE WITHOUT THE WRITTEN PERMISSION OF MITTLER BROS. MACHINE & TOOL IS PROHIBITED.

		UNLESS OTHERWISE SPECIFIED:		NAME	DATE	M3 MITTLER BROS. MACHINE & TOOL 10 Cooperative Way, Wright City, MO. 63390 (636)745-7757 Fax (636)745-2874
		DIMENSIONS ARE IN INCHES	DRAWN	BAB	2/22/11	
		TOLERANCES:	CHECKED			
		FRACTIONAL ±.015	ENG APPR.			
		ONE PLACE DECIMAL ±.015	MFG APPR.			
		TWO PLACE DECIMAL ±.010	Q.A.			TITLE:
		THREE PLACE DECIMAL ±.005	COMMENTS			180 Manual Tubing Bender
		ANGULAR ±1°				SIZE DWG. NO. REV
		QUANTITY				A 950 Retrofit Inst
		MATERIAL				SCALE: 1:4 WEIGHT: 21.843 SHEET 1 OF 2
		FINISH				
NEXT ASSY	USED ON					
APPLICATION		DO NOT SCALE DRAWING				

REQUIRED PART MODIFICATIONS

TOP PLATE MODIFICATION

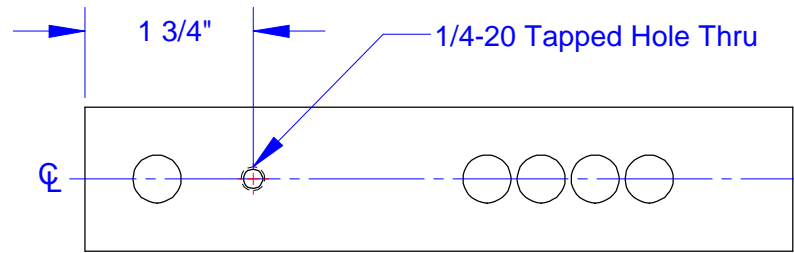

HANDLE ASSEMBLY MODIFICATION

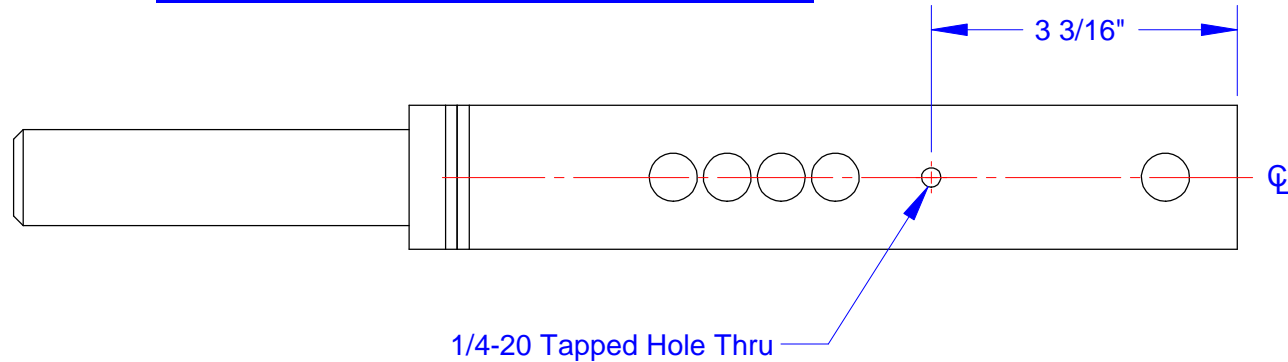

PROPRIETARY AND CONFIDENTIAL
 THE INFORMATION CONTAINED IN THIS DRAWING IS THE SOLE PROPERTY OF MITTLER BROS. MACHINE & TOOL. ANY REPRODUCTION IN PART OR AS A WHOLE WITHOUT THE WRITTEN PERMISSION OF MITTLER BROS. MACHINE & TOOL IS PROHIBITED.

		UNLESS OTHERWISE SPECIFIED:	NAME	DATE	 10 Cooperative Way, Wright City, MO. 63390 (636)745-7757 Fax (636)745-2874	
		DIMENSIONS ARE IN INCHES	DRAWN	BAB		2/22/11
		TOLERANCES:	CHECKED			
		FRACTIONAL ±.015	ENG APPR.			
		ONE PLACE DECIMAL ±.015	MFG APPR.			
		TWO PLACE DECIMAL ±.010	Q.A.			
		THREE PLACE DECIMAL ±.005	COMMENTS			
		ANGULAR ±1°				
		QUANTITY			TITLE:	
		MATERIAL			Required Modifications	
		FINISH			SIZE DWG. NO. REV	
NEXT ASSY	USED ON				A 950 Retrofit Inst	
APPLICATION		DO NOT SCALE DRAWING			SCALE: 1:3 WEIGHT: 1.425 SHEET 2 OF 2	