

ITEM NO.	PART NUMBER	Description	Default/ QTY.
1	950-A01	Handle Assembly	1
2	950-008	Follower	1
3	Bushing	Bushing	4
4	950-009	Pull Pin	1
5	950-007	Shoe	1
6	950-003	Top Plate	1
7	950-004	Bottom Plate	1
8	950-006-01 thr -21 round	Cam Lock Eccentric	1
9	950-101	Thin Delrin washer	1
10	950-102	Thick Delrin Washer	1
11	950-103	Degree Wheel	1
12	SHSSCREW 0.5x3.5-N	1/2" shoulder screw x 3-1/2"	2
13	HX-SHCS 0.25-20x0.75x0.75-N	1/4-20 x 3/4" SHCS	1
14	950-104	Screw Cap	1
15	HJNUT 0.2500-20-D-N	1/4-20 Jam Nut	1
16	0.25x0.51, Thumb Screw, Type A, Flat Point-N	1/4-20 x 1/2" Thumb Screw	1

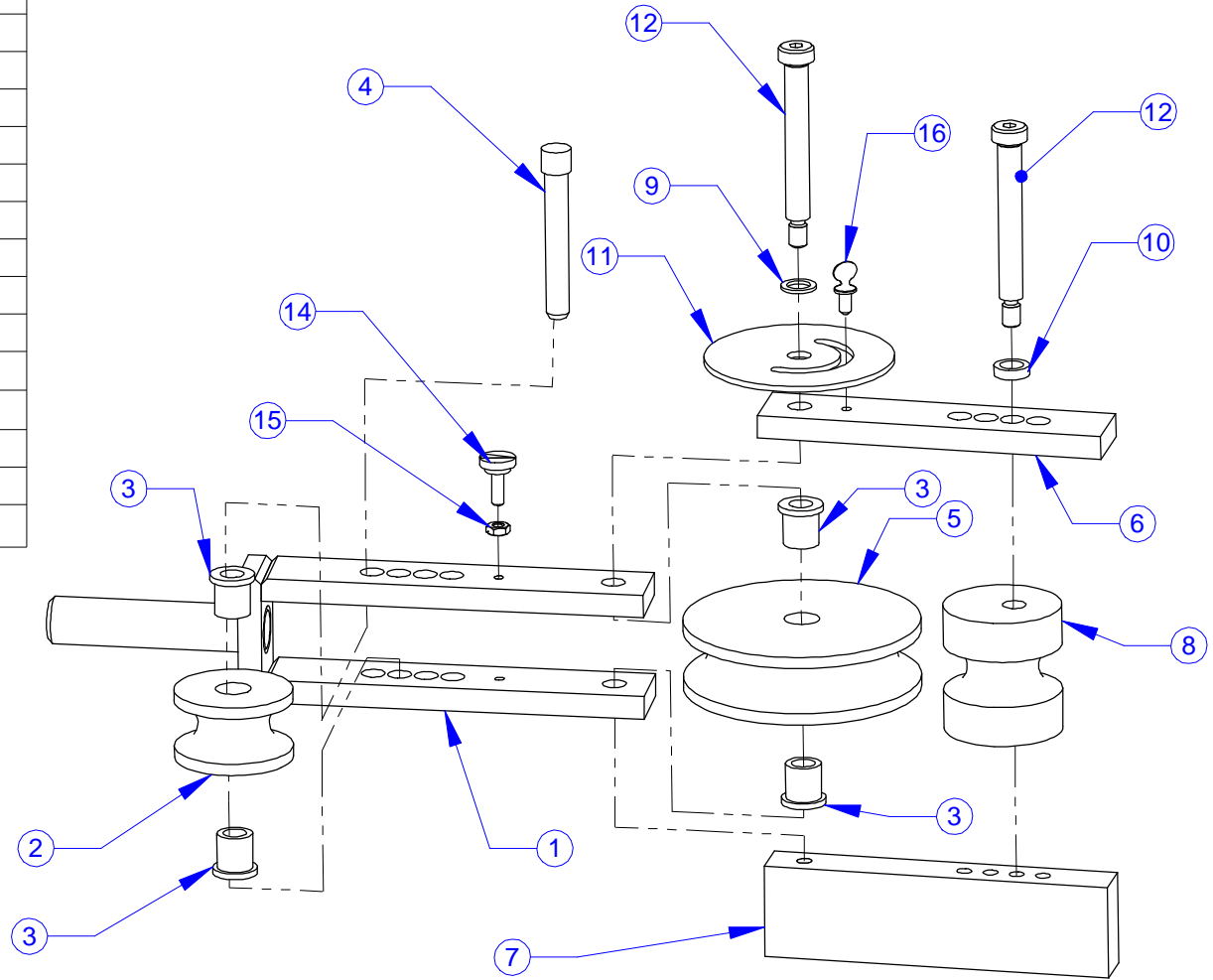

PROPRIETARY AND CONFIDENTIAL
 THE INFORMATION CONTAINED IN THIS DRAWING IS THE SOLE PROPERTY OF MITTLER BROS. MACHINE & TOOL. ANY REPRODUCTION IN PART OR AS A WHOLE WITHOUT THE WRITTEN PERMISSION OF MITTLER BROS. MACHINE & TOOL IS PROHIBITED.

		UNLESS OTHERWISE SPECIFIED:		NAME	DATE	M3 MITTLER BROS. MACHINE & TOOL 10 Cooperative Way, Wright City, MO. 63390 (636)745-7757 Fax (636)745-2874	
		DIMENSIONS ARE IN INCHES		DRAWN	BAB		2/22/11
		TOLERANCES:		CHECKED			
		FRACTIONAL ±.015		ENG APPR.			
		ONE PLACE DECIMAL ±.015		MFG APPR.			
		TWO PLACE DECIMAL ±.010		Q.A.			
		THREE PLACE DECIMAL ±.005		COMMENTS			
		ANGULAR ±1°					
		QUANTITY				TITLE: 180 Manual Tubing Bender	
		MATERIAL yyyy				SIZE DWG. NO. REV	
NEXT ASSY	USED ON	FINISH				A 950	
APPLICATION		DO NOT SCALE DRAWING				SCALE: 1:4 WEIGHT: 21.843 SHEET 1 OF 1	