

DETAIL A
SCALE 1 : 6

Clutch Lever

6
Connects to Clutch Lever
on Powerhammer Kit
See Detail A

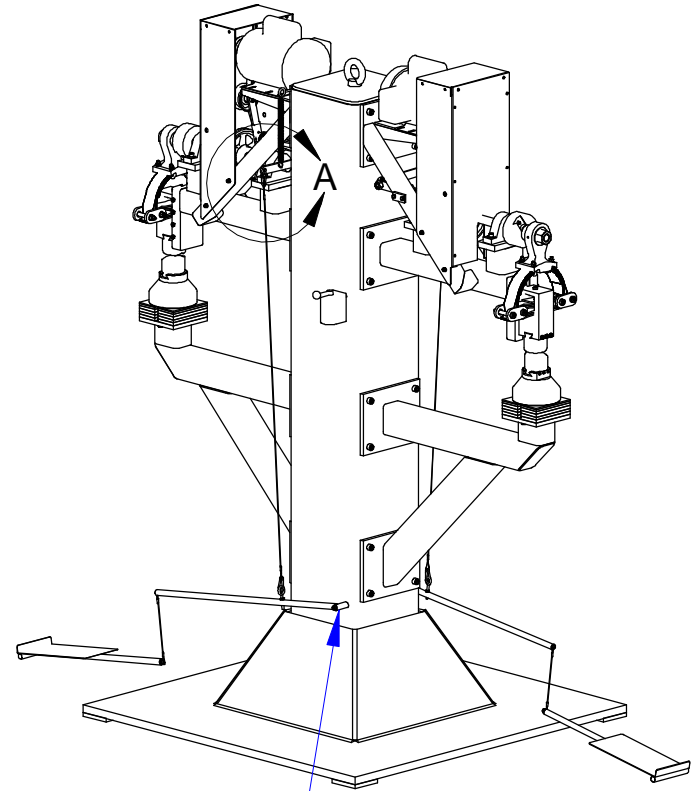

Connects to pedal
as shown

FASTENERS		
ITEM NO.	DESCRIPTION	QTY
10	1/4-20 Jam Nut	1
11	5/16-18 Nyloc Nut	1
12	5/16-18 x 5/8" BHCS	2
13	3/8 x 2" Shoulder Bolt	1

ITEM NO.	PART NUMBER	Description	QTY.
1	4200-260	Foot Pedal Assembly	1
2	4200-504	Foot Pedal Cable	1
3	4200-270	Clutch Lever Ankle	1
4	4200-503	Clutch/Brake Cable	1
5	4200-500	Eyebolt	1
6	4200-520	Cable End Link	2

PROPRIETARY AND CONFIDENTIAL
THE INFORMATION CONTAINED IN THIS DRAWING IS THE SOLE PROPERTY OF MITTLER BROS. MACHINE & TOOL. ANY REPRODUCTION IN PART OR AS A WHOLE WITHOUT THE WRITTEN PERMISSION OF MITTLER BROS. MACHINE & TOOL IS PROHIBITED.

		UNLESS OTHERWISE SPECIFIED: DIMENSIONS ARE IN INCHES TOLERANCES: FRACTIONAL ±.015 ONE PLACE DECIMAL ±.010 TWO PLACE DECIMAL ±.005 THREE PLACE DECIMAL ±.005 ANGULAR ±1°	DRAWN NAME DATE	MB MITTLER BROS. MACHINE & TOOL 10 Cooperative Way, Wright City, MO. 63390 (636)745-7757 Fax (636)745-2874	
		QUANTITY 1	CHECKED	TITLE:	
		MATERIAL yyyy	ENG APPR.	Foot Pedal/Clutch Lever Assem	
		FINISH	MFG APPR.	SIZE DWG. NO. REV	
NEXT ASSY	USED ON		Q.A.	A 4200-255	
APPLICATION		DO NOT SCALE DRAWING	COMMENTS	SCALE: 1:20 WEIGHT: 4.073 SHEET 1 OF 1	