

ITEM NO.	PART NUMBER	Description	Material	QTY.
1	4200-401	BASE FT PAD	1/2" x 4" x 4"	4
2	4200-402	BASE GUSSET PLATE	1/2" or 3/8"	4
3	4200-403	BASE PLATE	1" x 48" x 48"	1
4	4200-404	Base Mount Tube	12 x 12 x 1/2 Sq Tubing	1
5	4200-405	Cap	3/8"	1
6	4200-571	3/4-10 NUT	-	1
7	4200-570	3/4-10 Eyebolt	-	1

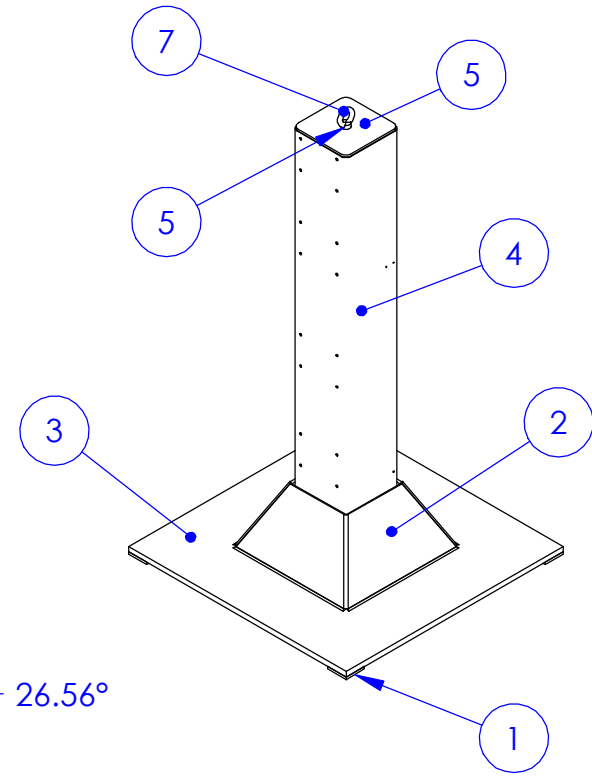
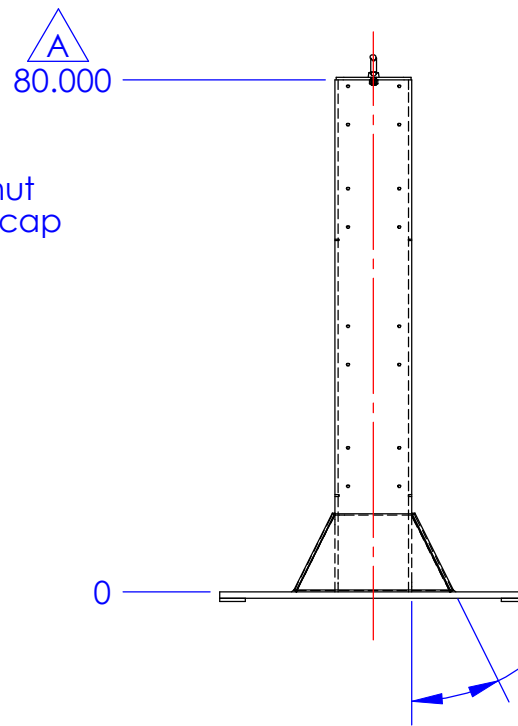
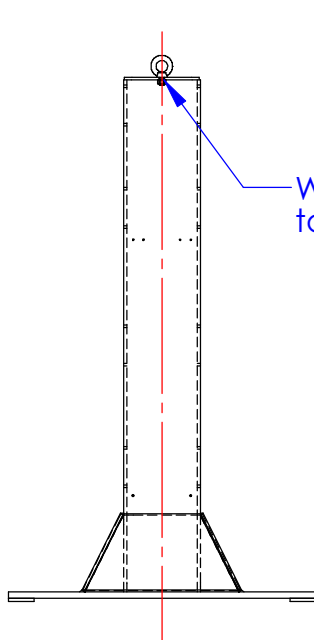

REVISIONS			
REV.	DESCRIPTION	DATE	BY
A	Tube was 84"	12/28/2010	BAB

PROPRIETARY AND CONFIDENTIAL
 THE INFORMATION CONTAINED IN THIS DRAWING IS THE SOLE PROPERTY OF MITTLER BROS. MACHINE & TOOL. ANY REPRODUCTION IN PART OR AS A WHOLE WITHOUT THE WRITTEN PERMISSION OF MITTLER BROS. MACHINE & TOOL IS PROHIBITED.

1/6/2011		UNLESS OTHERWISE SPECIFIED: DIMENSIONS ARE IN INCHES TOLERANCES: FRACTIONAL ±.015 ONE PLACE DECIMAL ±.015 TWO PLACE DECIMAL ±.010 THREE PLACE DECIMAL ±.005 ANGULAR ±1°		NAME	DATE
		QUANTITY		BAB	11/2/10
		MATERIAL		CHECKED	
		FINISH		ENG APPR.	
		NEXT ASSY	USED ON	MFG APPR.	
		APPLICATION	DO NOT SCALE DRAWING	Q.A.	
				COMMENTS	

M3 MITTLER BROS. MACHINE & TOOL
 10 Cooperative Way, Wright City, MO. 63390
 (636)745-7757 Fax (636)745-2874

TITLE:
PWR HMR BASE

SIZE DWG. NO. REV
A 4200-400 A

SCALE: 1:30 WEIGHT: SHEET 1 OF 1