

ITEM NO.	PART NUMBER	DESCRIPTION	QTY.
1	1100-001	Swivel Base	1
2	1100-018	Swivel	1
3	400-554	1/2 - 13 x 2 1/2 stud	2
4	.500 washer	1/2" Hard Washer	2
5	HNUT 0.5000-13-D-N	1/2"-13 Hex Nut	2
6	1100-008	Vise Base	1
7	1100-501	Vise Adj. Handle	1
8	400-519	Vise Screw Collar	1
9	1100-006	Clamp Screw	1
10	1100-002	Vise Head Block	1
11	1100-005	Vise Jaw Flat	1
12	SCHSCREW 0.3125-18x0.75x0.75-HX-N	5/16"-18 x 3/4" SHCS	2
13	5/16-24 x 1.25	SHCS (1100-S, SADJ, UADJ)	2
14	1100-004	Vise Runner	2
15	socket button head cap screw_ai	#10-32 x 1/2" SBHCS	4
16	1100-015	Std. Vise V Jaw (1100-S, SADJ, UADJ)	1
17	1100-014	Offset Vise V-Gib Block (1100-SADJ, UADJ)	1
18	1100-016	Offset Vise V-Gib (1100-SADJ, UADJ)	1
19	1100-020	Upgrade Adj. Vise Shim	1
20	1100-007	2in Pipe 2-1/2in Tube Jaw (1100-U)	1
21	5/16-24 x 1.50	SHCS (1100-U)	2

1100-S Standard Vise

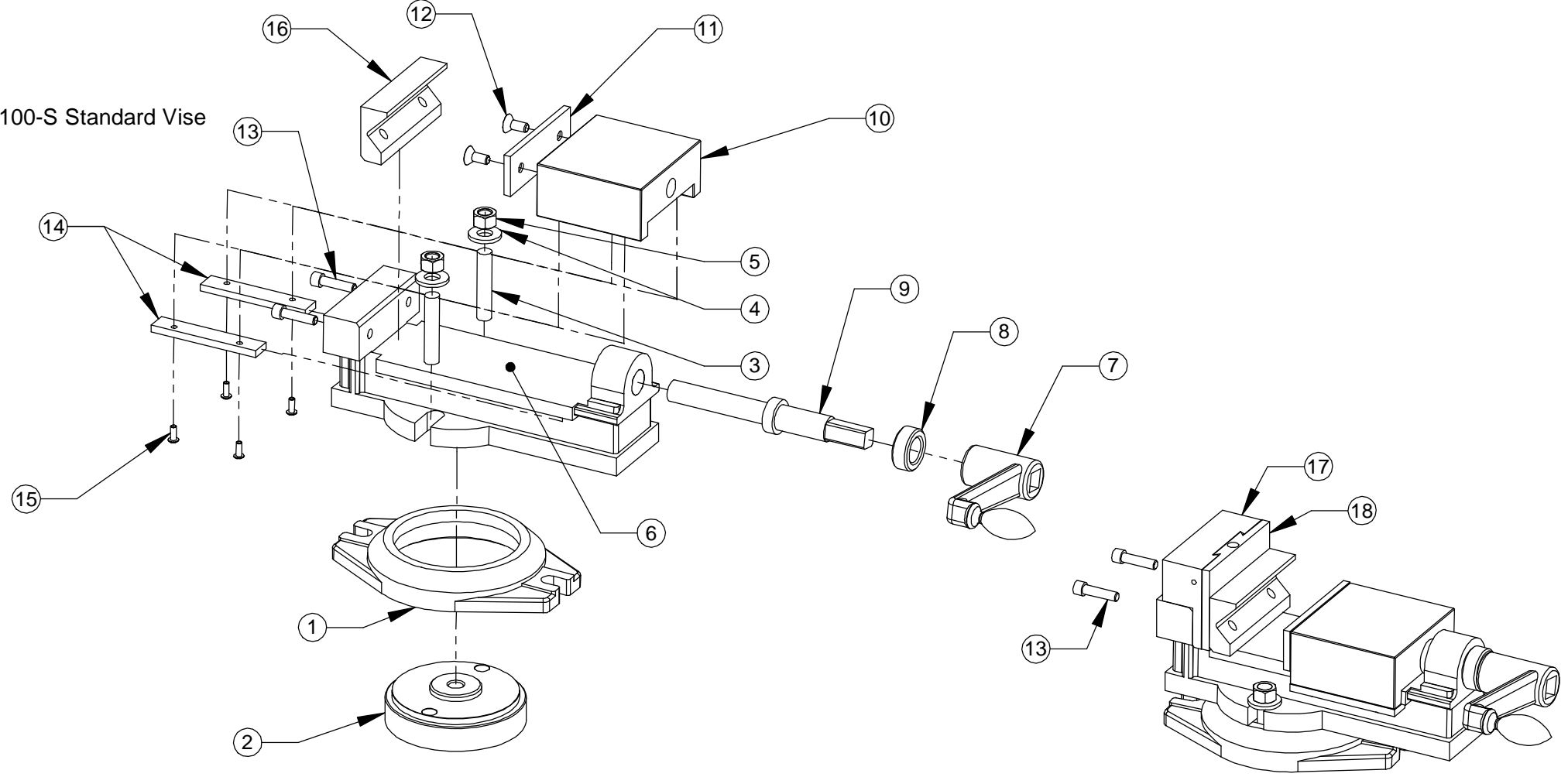

1100-SADJ Standard Adjustable Vise

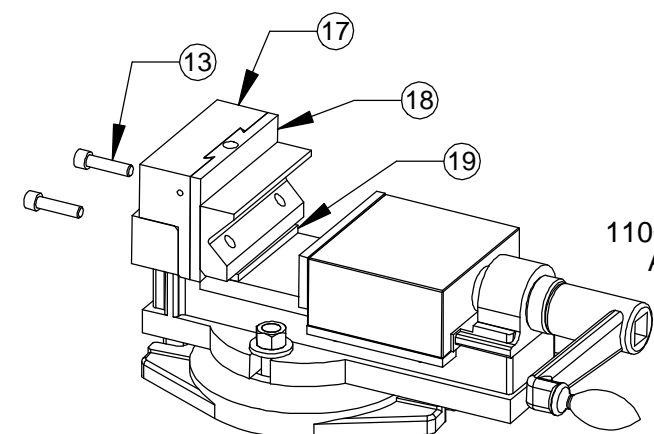

1100-UADJ Upgraded Adjustable Vise

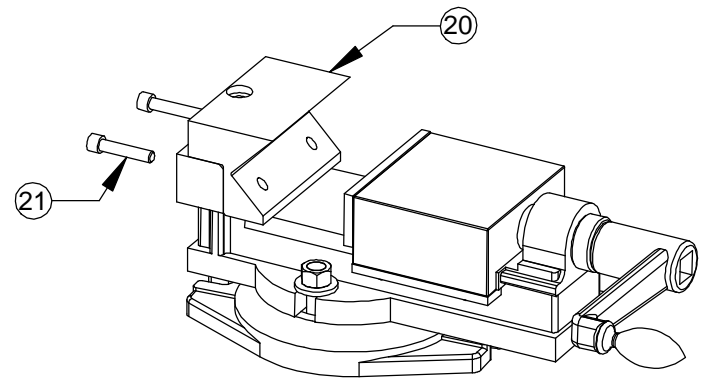

1100-U Upgraded Vise

PROPRIETARY AND CONFIDENTIAL
 THE INFORMATION CONTAINED IN THIS DRAWING IS THE SOLE PROPERTY OF MITTLER BROS. MACHINE & TOOL. ANY REPRODUCTION IN PART OR AS A WHOLE WITHOUT THE WRITTEN PERMISSION OF MITTLER BROS. MACHINE & TOOL IS PROHIBITED.

UNLESS OTHERWISE SPECIFIED:		NAME	DATE
DIMENSIONS ARE IN INCHES		RKH	4/2/07
TOLERANCES:		DRAWN	
FRACTIONAL ±.015		CHECKED	
ONE PLACE DECIMAL ±.015		ENG APPR.	
TWO PLACE DECIMAL ±.010		MFG APPR.	
THREE PLACE DECIMAL ±.005		Q.A.	
ANGULAR ± 1°			
QUANTITY			
MATERIAL	FINISH		
YYYY	LENGTH		
NEXT ASSY	USED ON	COMMENTS	
APPLICATION	DO NOT SCALE DRAWING		

MB MITTLER BROS. MACHINE & TOOL
 10 Cooperative Way, Wright City MO. 63390
 (636)745-7757 Fax (636)745-2874

TITLE: **Vise Assemblies**

SIZE DWG. NO. REV
B 400-A06

SCALE: 1:5 WEIGHT: 180.116 SHEET 1 OF 1