

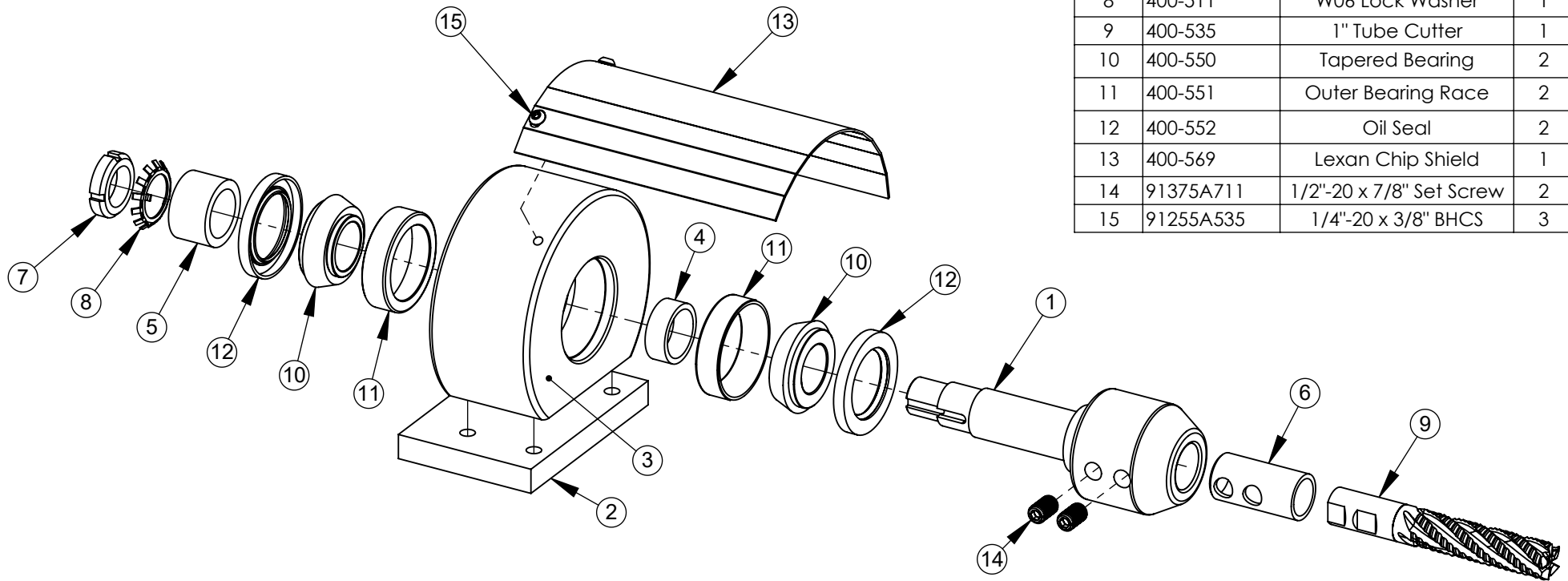

ITEM NO.	PART NUMBER	DESCRIPTION	QTY.
1	400-002	Chuck Spindle	1
2	400-007	Adapter Plate	1
3	400-008	Spindle Housing	1
4	400-017	Bearing Spacer	1
5	400-018	Seal Bushing	1
6	400-019	Spindle Sleeve Adapter (Optional)	1
7	400-510	N06 Locknut	1
8	400-511	W06 Lock Washer	1
9	400-535	1" Tube Cutter	1
10	400-550	Tapered Bearing	2
11	400-551	Outer Bearing Race	2
12	400-552	Oil Seal	2
13	400-569	Lexan Chip Shield	1
14	91375A711	1/2"-20 x 7/8" Set Screw	2
15	91255A535	1/4"-20 x 3/8" BHCS	3



PROPRIETARY AND CONFIDENTIAL
 THE INFORMATION CONTAINED IN THIS DRAWING IS THE SOLE PROPERTY OF MITTLER BROS. MACHINE & TOOL. ANY REPRODUCTION IN PART OR AS A WHOLE WITHOUT THE WRITTEN PERMISSION OF MITTLER BROS. MACHINE & TOOL IS PROHIBITED.

		UNLESS OTHERWISE SPECIFIED:	NAME	DATE	 10 Cooperative Way, Wright City, MO. 63390 (636)745-7757 Fax (636)745-2874	
		DIMENSIONS ARE IN INCHES	DRAWN	MSA		8/10/2017
		TOLERANCES:	CHECKED			
		FRACTIONAL ±.015	ENG APPR.			
		ONE PLACE DECIMAL ±.015	MFG APPR.			
		TWO PLACE DECIMAL ±.010	Q.A.			
		THREE PLACE DECIMAL ±.005	COMMENTS			
		ANGULAR ±1°				
		QUANTITY	TITLE:			
		MATERIAL	Spindle Assembly			
		FINISH	SIZE	DWG. NO.	REV	
NEXT ASSY	USED ON		A	400-A04	A	
APPLICATION		DO NOT SCALE DRAWING	SCALE: 1:4	WEIGHT: 20.496	SHEET 1 OF 2	

5

4

3

2

1