

ITEM NO.	PART NUMBER	DESCRIPTION	QTY.
1	400-012	Bushing Block	1
2	400-013-01	Steel V-Gib	1
3	400-013-02	Steel V-Gib	1
4	400-016	Standard Base Plate	1
5	400-512	Bronze Bushing	1
6	91251A581	3/8"-16 x 2" SHCS	8
7	98381A583	5/16" x 3/4" Dowel Pin	2
8	91375A636	3/8"-16 x 3" Set Screw	2

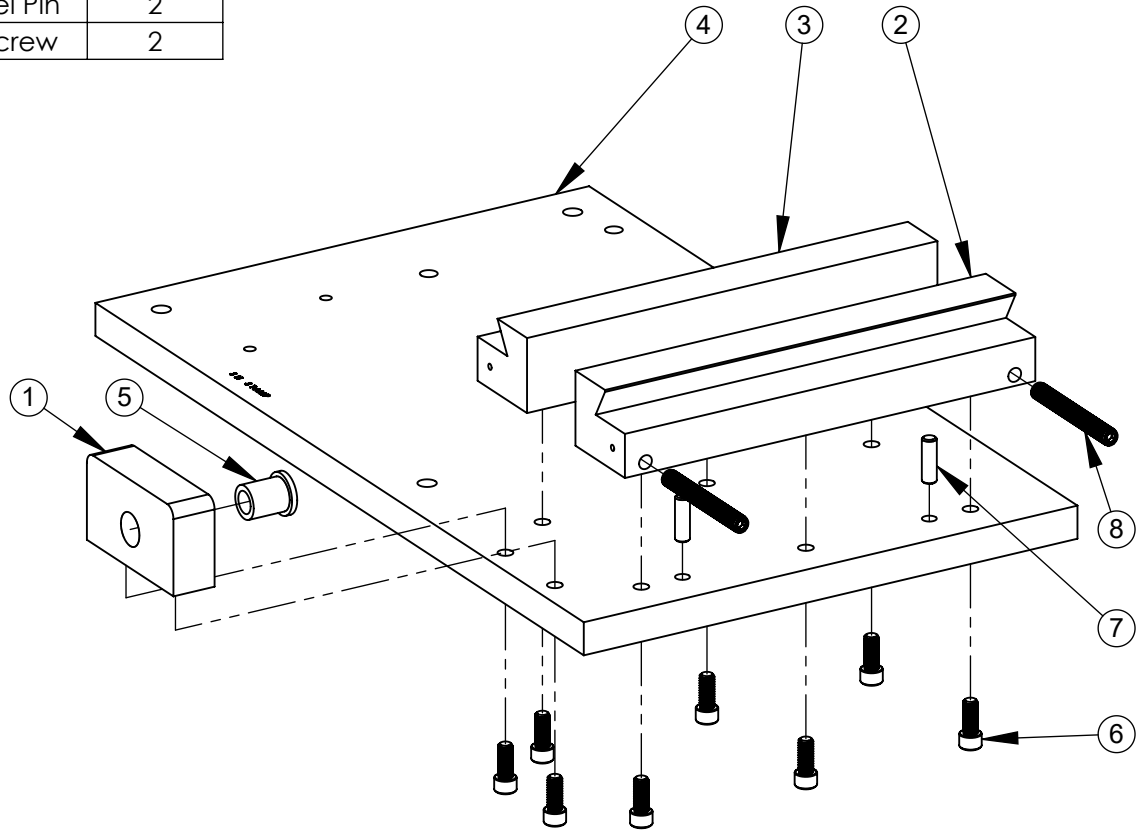

**PROPRIETARY AND CONFIDENTIAL**

THE INFORMATION CONTAINED IN THIS DRAWING IS THE SOLE PROPERTY OF MITTLER BROS. MACHINE & TOOL. ANY REPRODUCTION IN PART OR AS A WHOLE WITHOUT THE WRITTEN PERMISSION OF MITTLER BROS. MACHINE & TOOL IS PROHIBITED.

QUANTITY	
MATERIAL	
FINISH	

**DO NOT SCALE DRAWING**

NAME	DATE
MSA	7/12/19

**UNLESS OTHERWISE SPECIFIED:**

DIMENSIONS ARE IN INCHES  
 TOLERANCES:  
 FRACTIONAL ±1/32  
 ONE PLACE DECIMAL ±.015  
 TWO PLACE DECIMAL ±.010  
 THREE PLACE DECIMAL ±.005  
 ANGULAR ±1°

**COMMENTS:**

**M3 MITTLER BROS. MACHINE & TOOL**

10 Cooperative Way, Wright City, MO. 63390  
 (636)745-7757 Fax (636)745-2874

TITLE: <b>Base Assembly</b>		
SIZE <b>A</b>	DWG. NO. <b>400-A01</b>	REV
SCALE: 1:8	WEIGHT:	SHEET 1 OF 1