

ITEM NO.	PART NUMBER	Description	QTY.
1	400-013-02	Steel V-Gib	2
2	400-013-01	Steel V-Gib	2
3	400-016-DS	Base Plate, Double Side UTN	1
4	400-012	Bushing Block	2
5	HX-SHCS 0.3125-18x1x1-N	5/16"-18 x 1" SHCS	24
6	DPM 0.3125x1	Dowel Pin	4

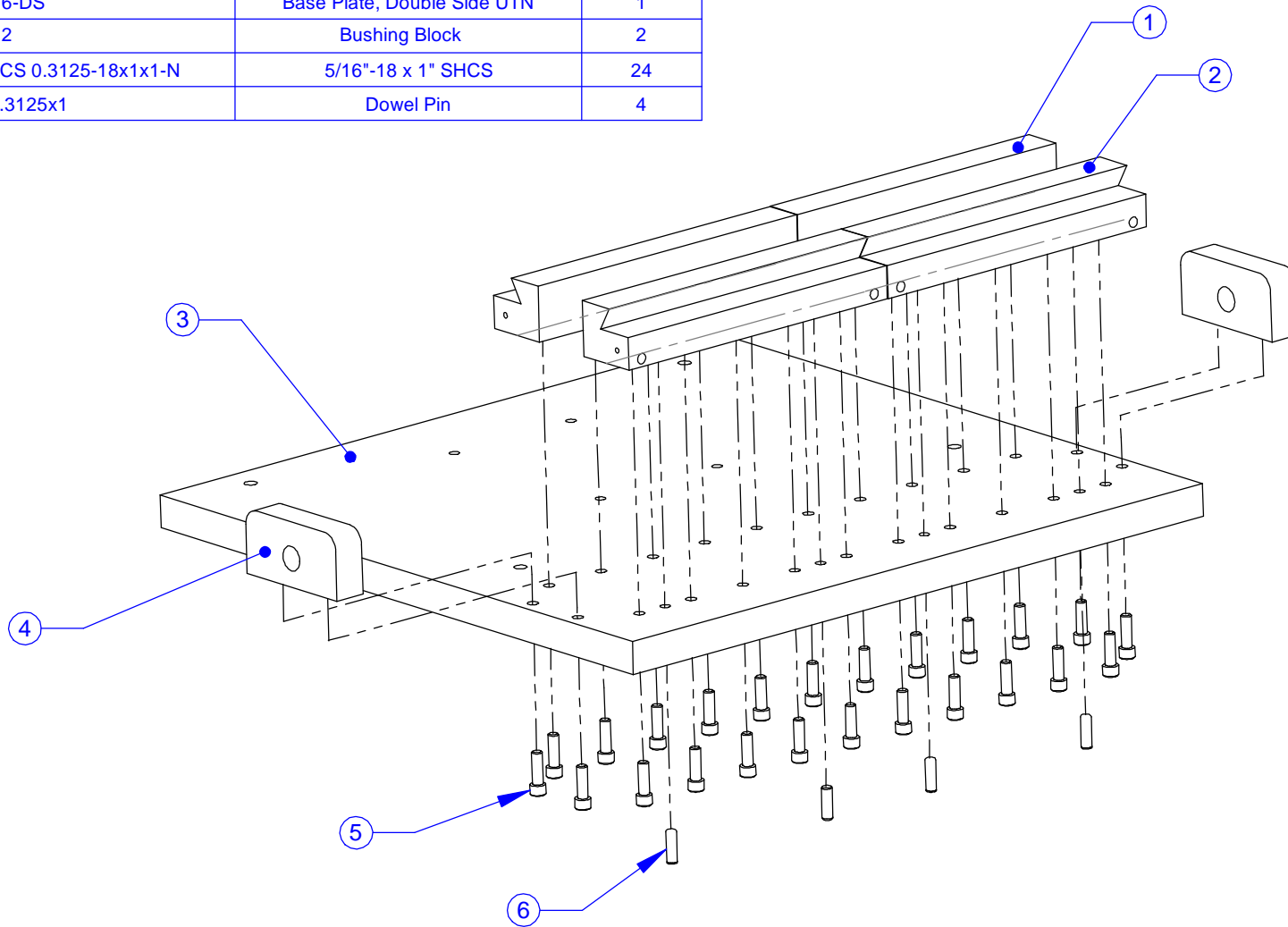

PROPRIETARY AND CONFIDENTIAL
 THE INFORMATION CONTAINED IN THIS DRAWING IS THE SOLE PROPERTY OF MITTLER BROS. MACHINE & TOOL. ANY REPRODUCTION IN PART OR AS A WHOLE WITHOUT THE WRITTEN PERMISSION OF MITTLER BROS. MACHINE & TOOL IS PROHIBITED.

		UNLESS OTHERWISE SPECIFIED:		NAME	DATE	MB MITTLER BROS. MACHINE & TOOL 10 Cooperative Way, Wright City, MO. 63390 (636)745-7757 Fax (636)745-2874
		DIMENSIONS ARE IN INCHES		DRAWN	BAB	
		TOLERANCES:		CHECKED		
		FRACTIONAL ±.015		ENG APPR.		
		ONE PLACE DECIMAL ±.015		MFG APPR.		
		TWO PLACE DECIMAL ±.010		Q.A.		
		THREE PLACE DECIMAL ±.005		COMMENTS		
		ANGULAR ±1°				
		QUANTITY				TITLE: Base Assembly - DS
		MATERIAL				SIZE DWG. NO. REV
NEXT ASSY	USED ON	FINISH				A 400-A01-DS
APPLICATION		DO NOT SCALE DRAWING				SCALE: 1:5 WEIGHT: SHEET 1 OF 1