

Vise Options for Double Sided Ultimate Tubing Notcher (Ref. Drawing 400-A06)		
Double Sided Ultimate Tubing Notcher Model #	Included Vise Model #	Vise Description
400-VS2	1100-S	Standard Vise
400-VS2ADJ	1100-SADJ	Adjustable Vise
400-VSU2	1100-U	Upgraded Vise
400-VSU2ADJ	1100-UADJ	Upgraded Adjustable Vise

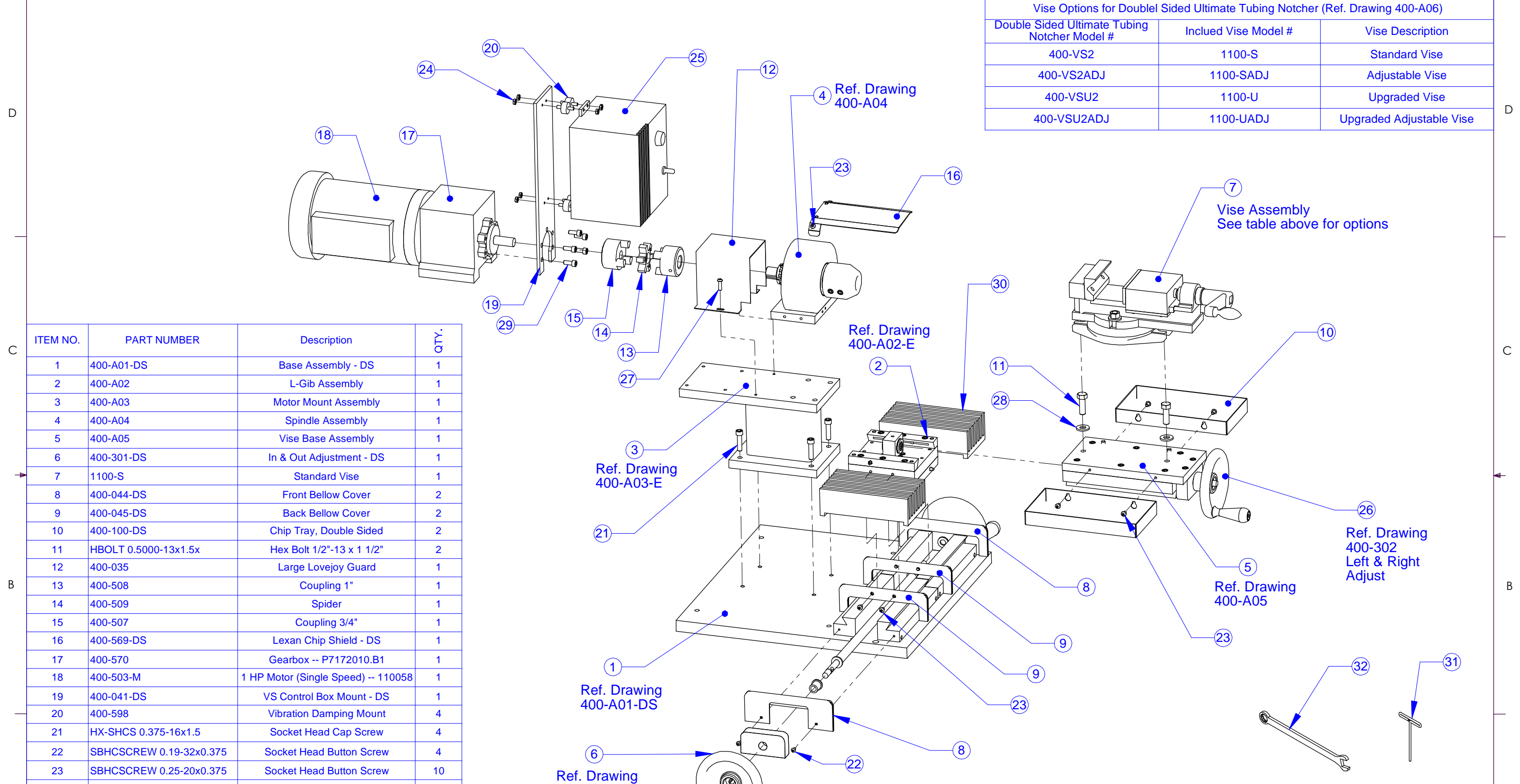

ITEM NO.	PART NUMBER	Description	QTY.
1	400-A01-DS	Base Assembly - DS	1
2	400-A02	L-Gib Assembly	1
3	400-A03	Motor Mount Assembly	1
4	400-A04	Spindle Assembly	1
5	400-A05	Vise Base Assembly	1
6	400-301-DS	In & Out Adjustment - DS	1
7	1100-S	Standard Vise	1
8	400-044-DS	Front Bellow Cover	2
9	400-045-DS	Back Bellow Cover	2
10	400-100-DS	Chip Tray, Double Sided	2
11	HBOLT 0.5000-13x1.5x	Hex Bolt 1/2"-13 x 1 1/2"	2
12	400-035	Large Lovejoy Guard	1
13	400-508	Coupling 1"	1
14	400-509	Spider	1
15	400-507	Coupling 3/4"	1
16	400-569-DS	Lexan Chip Shield - DS	1
17	400-570	Gearbox -- P7172010.B1	1
18	400-503-M	1 HP Motor (Single Speed) -- 110058	1
19	400-041-DS	VS Control Box Mount - DS	1
20	400-598	Vibration Damping Mount	4
21	HX-SHCS 0.375-16x1.5	Socket Head Cap Screw	4
22	SBHCSCREW 0.19-32x0.375	Socket Head Button Screw	4
23	SBHCSCREW 0.25-20x0.375	Socket Head Button Screw	10
24	HJNUT 0.2500-20-D-N	Hex Jam Nut	6
25	400-597	Variable Speed Control Box	1
26	400-302	Repair Kit	1
27	SBHCSCREW 0.25-20x0.875	Socket Head Button Screw	2
28	.500 washer	1/2" Washer	2
29	B18.3.1M - 8 x 1.25 x 20 Hex SHCS	Metric Socket Head Cap Screw	5
30	400-602	Retangular Bellow	2
31	1100-505	1/4" T-Handle Allen Wrench	1
32	1100-504	3/4" Wrench	1

PROPRIETARY AND CONFIDENTIAL  
 THE INFORMATION CONTAINED IN THIS DRAWING IS THE SOLE PROPERTY OF MITTLER BROS. MACHINE & TOOL. ANY REPRODUCTION IN PART OR AS A WHOLE WITHOUT THE WRITTEN PERMISSION OF MITTLER BROS. MACHINE & TOOL IS PROHIBITED.

UNLESS OTHERWISE SPECIFIED:		NAME	DATE
DIMENSIONS ARE IN INCHES		DRAWN	BAB 11/23/11
TOLERANCES:		CHECKED	
FRACTIONAL ±.015		ENG APPR.	
ONE PLACE DECIMAL ±.015		MFG APPR.	
TWO PLACE DECIMAL ±.010		Q.A.	
THREE PLACE DECIMAL ±.005			
ANGULAR ± 1°			
QUANTITY	MATERIAL	FINISH	LENGTH
	YYYY		
NEXT ASSY	USED ON	COMMENTS	
APPLICATION	DO NOT SCALE DRAWING		

**MB MITTLER BROS. MACHINE & TOOL**  
 10 Cooperative Way, Wright City MO. 63390  
 (636)745-7757 Fax (636)745-2874

TITLE:  
**Double Sided UTN**

SIZE DWG. NO. REV  
**B 400-A00-DS**

SCALE: 1:8 WEIGHT: 632.296 SHEET 1 OF 1