

### English Wheel Options

2900  
Complete assembled  
English Wheel

2900-K  
Includes machined parts  
and unwelded, nonpainted  
frame pieces

2900-KM  
Includes machined parts  
only, no frame pieces

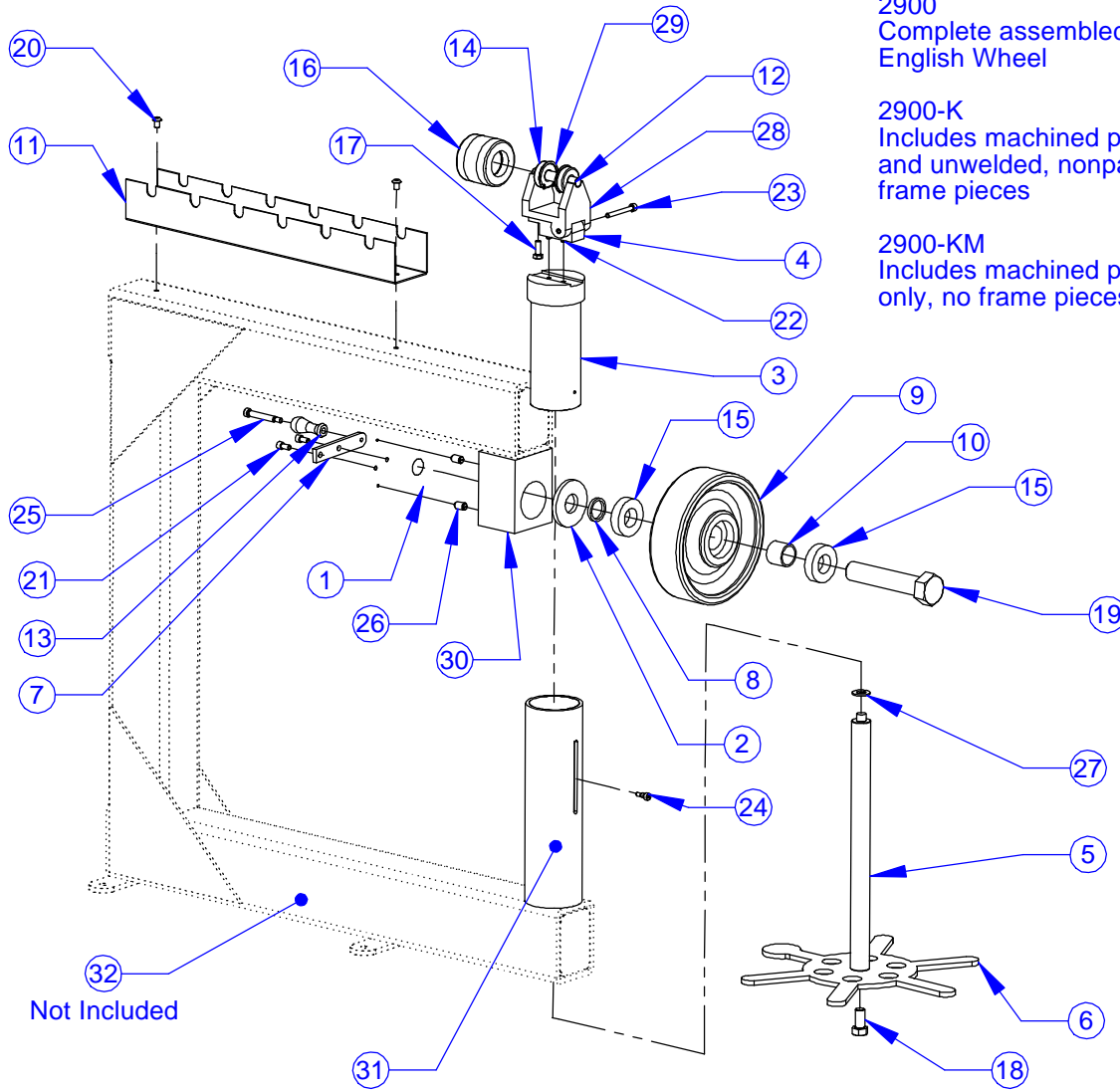

ITEM NO.	PART NUMBER	DESCRIPTION	QTY.
1	2900-001	Cam	1
2	2900-002	Cam Washer	1
3	2900-006	Riser	1
4	2900-007	Tilt Base	1
5	2900-011	Anvil Lift Bolt	1
6	2900-012	Kick Wheel	1
7	2900-019	Release Handle	1
8	2900-020	Washer	1
9	2900-021	English Wheel	1
10	2900-022	Inside Spacer	1
11	2900-023	Roll Tray	1
12	2900-025	Anvil Wheel Pin	1
13	2900-110	Handle	1
14	2900-501	Anvil Wheel Bearing, 22208-77	2
15	2900-502	R16 2RS Upper Wheel Bearing	2
16	2900-1	Anvil Roll 3/4" Flat	1
17	1 1/4"-20 x .750"	Hex Machine Bolt	1
18	1 1/2"-13 x 1.00"	Hex Machine Bolt	1
19	1"-8 x 5.00"	Hex Machine Bolt	1
20	BHCS	1/4" x .5" Button Head Screw	2
21	1 1/4-20 x .50	SHCS	2
22	1 1/4-20 x 1.00	SHCS	2
23	M6-1 x 50	SHCS	1
24	1 1/4" x .250"	Socket Shoulder Screw	1
25	5/16" x 1.75"	Socket Shoulder Screw	1
26	Spring Detent	3/8" Dia. x 5/8" Spring Detent	2
27	2900-026	Riser Bearing NTA-815	1
28	3200-313	Tilt Platform	1
29	2900-503	Rotor Clip HO-137 Snap Ring	2
30	2900-003	Top Wheel Support Block	1
31	2900-004	Anvil Support Block	1
32	2900-A10	Frame Weldment (Not Included)	1

Not Included

6 Anvil Wheels Included  
2-1/2" Dia x 2" Wide:  
2900-A0 = Flat  
2900-A1 = 12" Rad w/ 3/4" Flat  
2900-A2 = 8-1/2" Rad w/ 1/2" Flat  
2900-A3 = 5" Rad w/ 3/8" Flat  
2900-A4 = 3-1/4" Rad w/ 1/4" Flat  
2900-A5 = 2-3/8" Rad w/ 1/8" Flat  
CNC Machined Heat Treated Steel

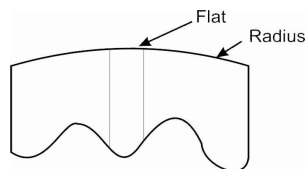

**PROPRIETARY AND CONFIDENTIAL**  
THE INFORMATION CONTAINED IN THIS DRAWING IS THE SOLE PROPERTY OF MITTLER BROS. MACHINE & TOOL. ANY REPRODUCTION IN PART OR AS A WHOLE WITHOUT THE WRITTEN PERMISSION OF MITTLER BROS. MACHINE & TOOL IS PROHIBITED.

4/27/11			NAME	DATE
		DRAWN	BAB	3/22/11
		CHECKED		
		ENG APPR.		
		MFG APPR.		
		Q.A.		
		COMMENTS		
NEXT ASSY	USED ON			
DO NOT SCALE DRAWING				

**M3 MITTLER BROS. MACHINE & TOOL**  
10 Cooperative Way, Wright City, MO. 63390  
(636)745-7757 Fax (636)745-2874

TITLE:  
**English Wheel**

SIZE	DWG. NO.	REV
<b>A</b>	2900-KM	

SCALE: 1:10 | WEIGHT: 115.819 | SHEET 1 OF 1