

Operating, Servicing, and Safety Instruction Manual Sheet Metal Straight Brake



16Ga Models #2800-4816S / #2800-7216S / #2800-9616S



22Ga Models #2800-7222S / #2800-9622S

CAUTION: Read and Understand

These Operating, Servicing, and
Safety Instructions, Before Using
This Machine.

1-800-467-2464

10 Cooperative Way Wright City, MO 63390

P.O. Box 110 Foristell, MO 63348

1-636-745-7757 Fax 1-636-745-2874

www.mittlerbros.com



16Ga Model# 2800-4816S

Total Shipping Weight: 715 lbs

MAX CAPACITY:

16Ga (.062") Mild Steel

12Ga (.080") Aluminum

20Ga (.038") Stainless Steel



16Ga Model# 2800-7216S

Total Shipping Weight: 1000 lbs

MAX CAPACITY:

16Ga (.062") Mild Steel

12Ga (.080") Aluminum

20Ga (.038") Stainless Steel



16Ga Model# 2800-9616S

Total Shipping Weight: _____ lbs

MAX CAPACITY:

16Ga (.062") Mild Steel

12Ga (.080") Aluminum

20Ga (.038") Stainless Steel



**22Ga Model# 2800-7216S &
22Ga Model# 2800-9616S**

2800-7216S Total Shipping Weight: 450 lbs

2800-9616S Total Shipping Weight: 705 lbs

MAX CAPACITY:

22Ga (.030") Mild Steel

18Ga (.040") Aluminum

SAFETY

The purpose of the safety section of this manual is to inform operators and maintenance personnel of the precautions to be taken while operating or servicing the machine. The following are a few basic guidelines to follow, but as with any type of machinery good judgment and a safe attitude should be applied at all times.

1. Always wear safety clothing, including eye protection and protective footwear, while operating or servicing the machine.
2. Keep all body parts and any foreign objects away from the nose bar and clamping area of the brake while in operation.
4. Never use a pipe or bar on the clamp handles for additional leverage.
5. Keep clear of the counterweight and apron swing area while operating the brake.
6. Keep the work area around the brake clear and clean to avoid slipping or tripping.
5. Do not operate the machine if it has been damaged or is not operating properly.
6. Do not wear jewelry (watches, rings, necklaces, etc.), or loose fitting clothing while operating or servicing the machine.
7. The machine should only be operated or serviced by properly trained, authorized personnel.
8. Replacement parts should have the same specification and operation as the original parts on the machine.
9. All guards and covers must be in place before operating the machine.
10. Be sure brake is set on smooth, level floor & is set up properly.
11. Do not operate or service any machine while under the influence of drugs or alcohol.

NOTE: THESE SAFETY RULES ARE FOR YOUR BENEFIT TO HELP PREVENT INJURY TO YOURSELF AND/OR YOUR CO-WORKERS. REVIEW ALL SETUP AND OPERATING PROCEDURES, WHETHER COVERED OR NOT, IN THIS MANUAL TO HELP INSURE SAFE OPERATION OF THE MACHINE.

INSTALLATION

RECEIVING

Use caution in handling and moving the brake. The brake weighs several hundred pounds and is top-heavy. Handling should be performed with proper equipment such as a fork lift or hoist. **Do not insert forks between the pallet and the bottom of the brake.**



INSTALLATION

- Locate the brake in a well-lighted area on a solid level floor, (bench mount on a stand or work bench) capable of supporting the Brake total weight – see page 2.
- It is recommended that the Brake be secured to the floor by bolts or lag screws.
- Be certain that there is adequate clearance to swing the apron and counterweights.

Mittler Bros. Machine & Tool offers a Floor Stand (#2800-400) for the 48" Bench Mount Brake. This bench includes the following features: provides a sturdy base designed specifically for the brake, easy attachment of the brake to the stand, pre-drilled holes for attaching the stand to the floor, sets the working height of the brake to an ergonomic 38".

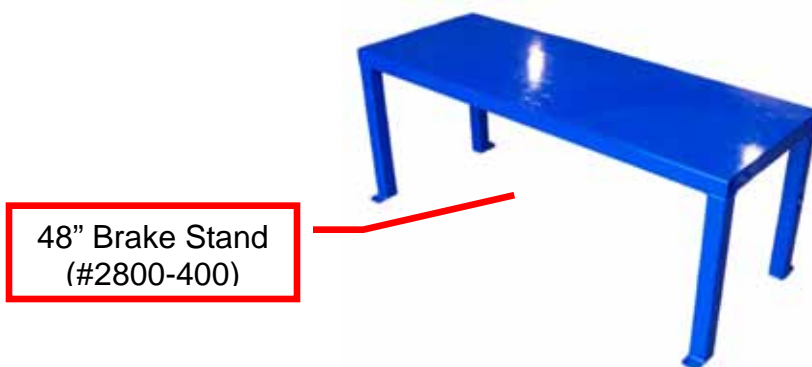

ASSEMBLY

The brake requires only minor assembly for proper operation. Place the counterweight(s) in the tube on the apron assembly so that the apron is balanced and resting against the lower brake frame. Tighten the two set screws in the tube to secure the counterweight(s) in place.



COMPONENT IDENTIFICATION:

The basic components of a brake are:

Lower Frame / Legs – the lower base frame / support legs

Upper Clamp Head – top clamp which holds material being formed;

Apron (Leaf) – the front plate which you swing up to form material.

Counterweight – balances apron to reduce apron weight and assist in lifting apron

Clamp Handles – raises and lowers Upper Clamp Head

Upper Adjusting Nut – adjusts lift of Upper Clamp Head

Lower Adjusting Nut – adjusts clamping pressures against metal

Lock Handle – prevents in advertent set back adjustment when tightened.

Adjusting Bracket Screw – moves Upper Clamp Head forward / rearward to establish set back.

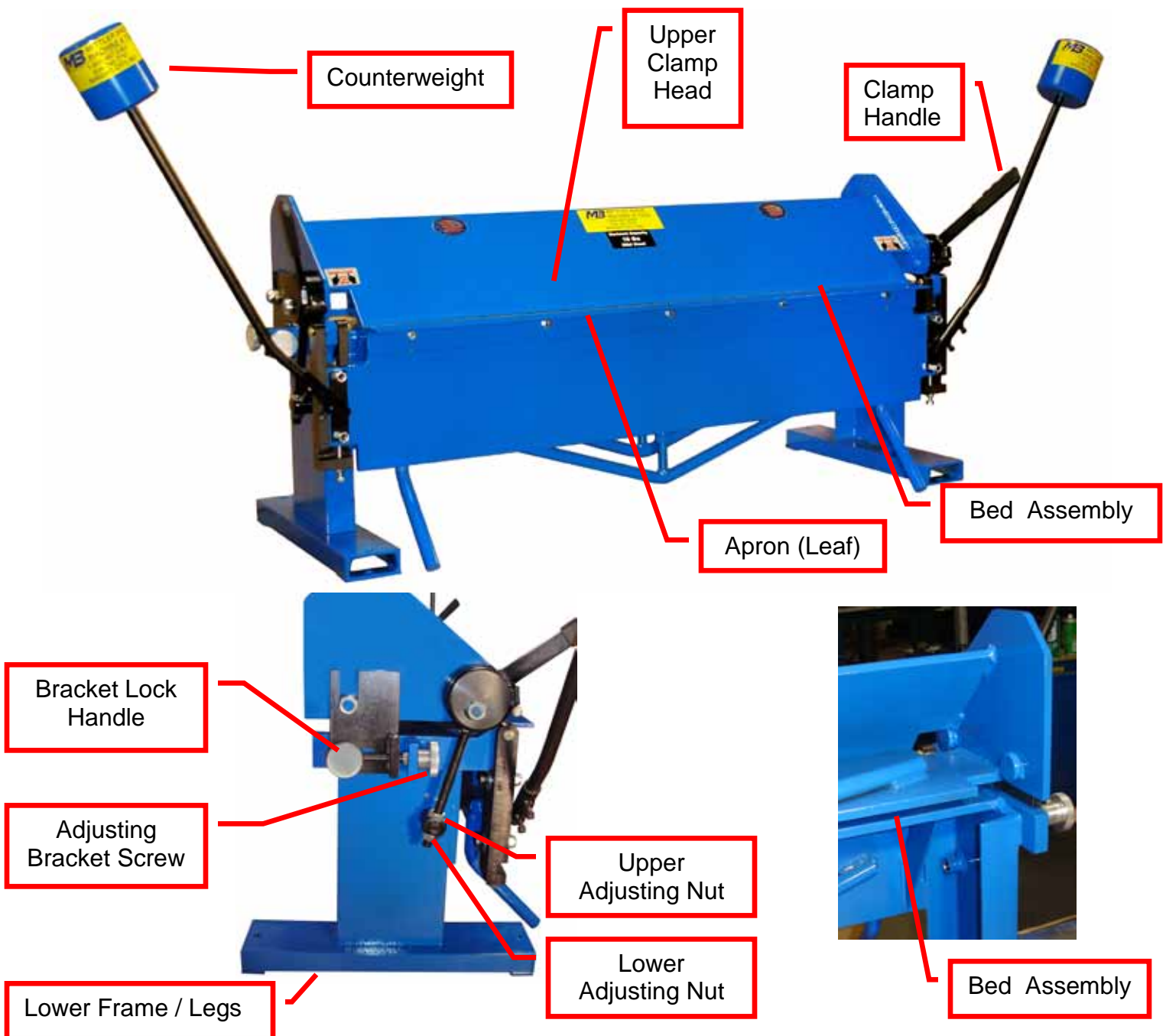

PRINCIPLES OF OPERATION

Clamp Pressure: Pressure applied with Upper Clamp Head.

NOTE: Apply only enough clamp pressure to hold the metal from moving or slipping.

Set Back: Distance Front Edge of Upper Pinch Head is back away from Apron Pivot point.

General Rule:

18 Gauge (0.050") or less metal thickness = 1-1/2 times the material thickness.

16 Gauge (0.060") or more metal thickness = 2 times material thickness.

PRECAUTIONS:

- 1) Read and understand the safety instructions on page 3 of this manual before proceeding.
- 2) Always adjust the set back clearance and clamping pressure for different thicknesses of material.
- 3) Always bend short pieces of material in the center of the brake in order to equalize the stress and avoid damage to the brake.
- 4.) Do Not bend rods, nails, or wire in Brake. This will damage the clamp finger(s) and apron.
- 5.) Do Not bend hems or seams unless the clamp pressure adjustment is changed to handle the extra (double) metal thickness.
- 6.) Use your legs and arms when making bends, similar to lifting heavy objects, to avoid back strain.

ADJUSTMENTS

When your brake was assembled at the factory it was adjusted for proper operation. Due to handling and repositioning, the brake may require adjustment and alignment. Read the adjustment and operating instructions completely before making any adjustments. Operate the brake and bend some material first before attempting any major adjustment.

For the following adjustment, use test strips of metal, each approximately 3 inches by 3 inches, of the thickness being formed.

Over-bending

Check end-to-end alignment by clamping two test strips in the brake, about 3 or 4 inches away from either end of the brake. Bend to about 90 degrees, and see if they appear to be bent to the same degree. Remove them from the brake and stack one inside the other. Compare the sharpness of the radius. If one test strip is over-bent or has a sharper radius, slightly move the end of the clamp head which that strip came from. The clamp assembly should be moved back on the end where the over-bending occurs by slightly unclamping the clamp handle, loosening the bracket lock screw and turning the adjusting bracket screw. When the correction is made, retighten the bracket lock screw.

OPERATION

Your brake is a general purpose tool for bending and forming sheet metal. The brake is operated in the following manner. The Upper Clamp Head of the brake is opened by pushing the clamp handles toward the rear of the brake. Insert the material to be bent into the opening between the Upper Clamp Head and Bed Table and clamp the material in place by pulling the clamp handles forward. Raise the apron to bend the material to the desired angle.

Capacity

16 Gauge

#2800-4816S / #2800-7216S / #2800-9616S = 16 Ga mild steel (0.063"), 14 Ga aluminum (0.064"), or 20 Ga stainless steel (0.037").

22 Gauge

#2800-7222S / #2800-9622S = 22 Ga mild steel (0.032"), 18 Ga aluminum (0.040").

Step 1: Clamping Pressure

Check clamping pressure by clamping test strips in the brake approximately 3 or 4 inches away from each end of the brake. Clamping pressure should be enough to keep the material from slipping during a bend. Do Not Use excessive clamping pressure. Excessive clamp pressure causes most bending and forming problems.

Clamping pressure can be adjusted by loosening the top lock nut and adjusting the bottom nut to increase or decrease the clamp pressure.

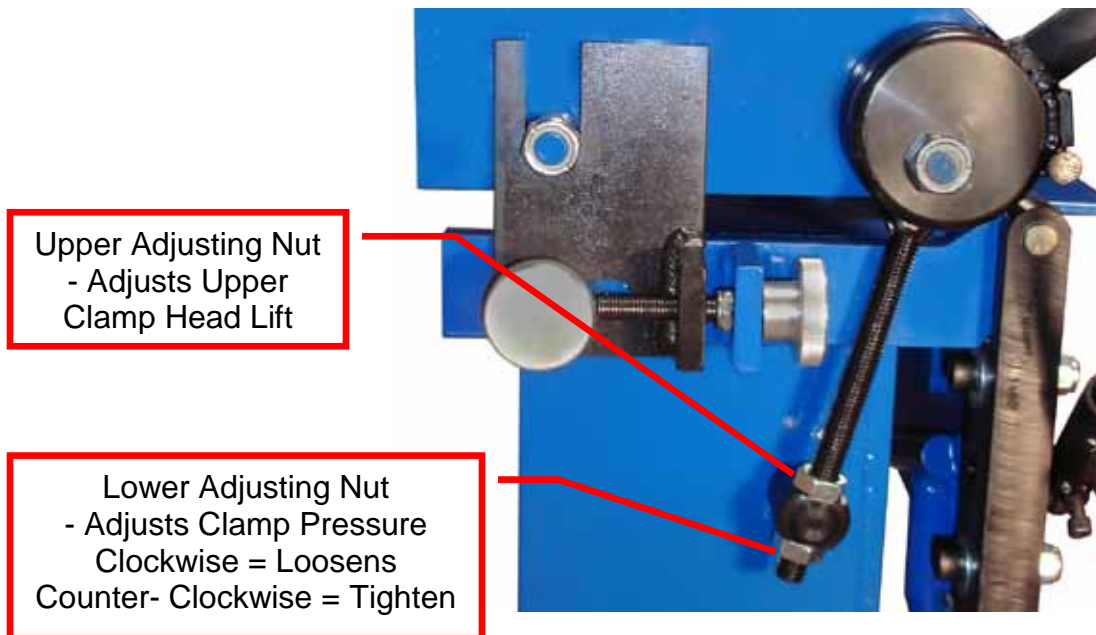

Clamping pressure should be adjusted for the thickness of the material being worked. Clamping pressure should be adequate to hold the material securely in place but not so great as to require undue effort in locking the clamp handles.

Step 2: Allowing for Metal Thickness

The Upper Clamp Assembly must be adjusted to allow for clearance based on the material thickness to be worked.

- Slightly unclamp the clamp handle, loosen the bracket lock screw and turn the adjusting bracket screw to move the Upper Clamp Head forward or rearward.
- Move the clamp back from the apron at least one and one half times the thickness of material being formed when forming up to 18 gauge (.050) material, and at least 2 times the thickness of material being formed when forming 16 gauge (.0625) or more. Re-check clamping pressure.
- Retighten the bracket lock screw, after the correction is made.
- Lock the bracket locking handles for repeat bends.

General Rule:

18 Gauge (0.050") or less metal thickness = 1-1/2 times the material thickness.

16 Gauge (0.060") or more metal thickness = 2 times material thickness.

CAUTION:

If the Upper Clamp Head is too close to the front edge of the Bed, the Clamp Head may be damaged. If the Upper Clamp Head is too far from the front edge of the Bed, a larger radius may be made in the material.

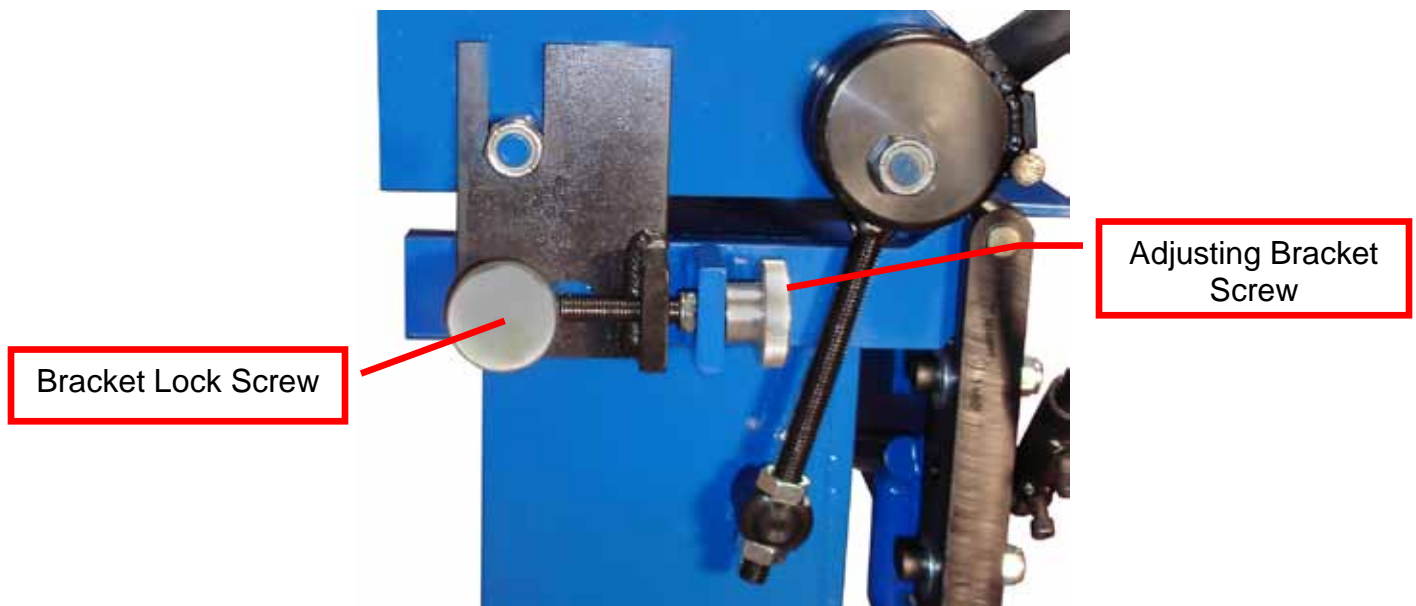

Hemming

The brake may be used to form hems on the edge of the work-piece in lighter materials. A hem is formed by making an acute (reverse) bend in the work-piece (apron and then clamping the bend flange under the Upper Clamp Head to press the flange closed (to 180 degrees). Often the hem will not fully close in the center of a long piece due to the fact that the outer ends of the brake are more rigid than the center. This situation can be improved by inserting a strip of material (of the same thickness as the work-piece) between the work-piece and the Upper Clamp Head slightly longer than the open portion of the hem. Re-clamp the Upper Clamp Head to close the hem. A tinner's mallet or hammer is also useful for closing hems. Use caution not to use excessive force on the clamp handles to close the hem.

NOTE: Forming hems is a secondary operation for a hand brake. If you adjust the brake to close a hem in the center of the work-piece the brake most likely will not bend straight.

MAINTENANCE

Lubrication

Use good grade of general purpose grease on all slide assemblies and pivot points.

Alignment & Adjustments

The Brake has three (3) truss rods to allow adjustment of the three (3) primary welded components. Adjustments are completed by adjusting the nut on the center truss rod of each welded component.



Apron & Bed Adjustment Nuts



Upper Clamp Head Adjustment Nut



Adjustment Nuts

Primary Alignment -- The Upper Clamp Head must be straight the entire distance across the Upper Clamp Head. This is the reference for all other alignments on the Brake. Raise or lower the center of the Upper Clamp Head by adjusting the nut on the center truss rod.

Hold Down Alignment – The forward edge of the Upper Clamp Head must be even and parallel to the front edge of the Bed Table. Release the clamp pressure at each end slightly, loosen the bracket lock screws on each end, and turn the adjustment bracket screws on each end to move the Upper Clamp Head front edge in alignment with the Bed Table front edge. Apply light pressure between the Upper Clamp Head and the Bed Table and check the Upper Clamp Head front edge to Bed Table front edge alignment. Raise or lower the center of the Bed Table by adjusting the nut on the Bed Table center truss rod.

Apron (Leaf) Adjustment – The center of the Apron Head / Angle must align with the front edge of the Bed Table. Raise or lower the center of the Apron Head / Angle by adjusting the nut on the Apron truss rod.

Apron Angle to Bed Alignment

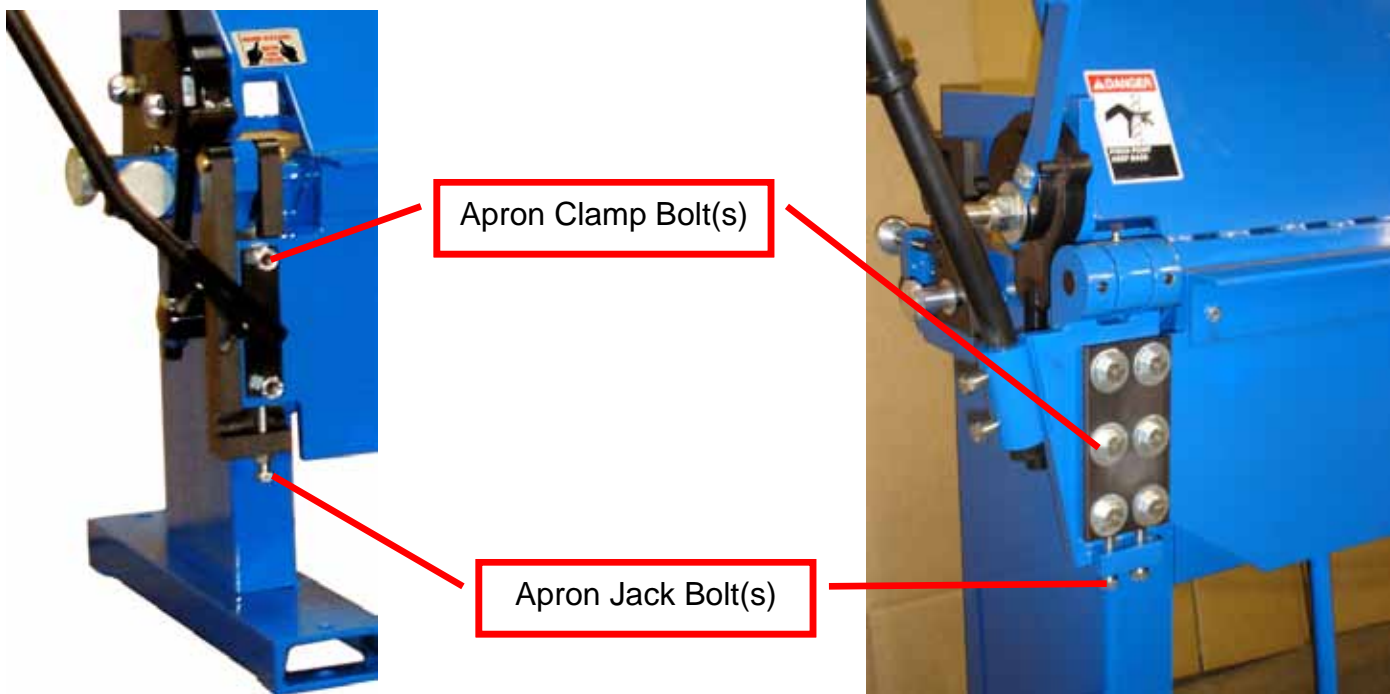

The top of the Apron Head / Angle must be parallel and level with the Bed Table.

To raise or lower each Apron end:

- Loosen the jack bolt jam nut(s)
- Loosen Apron to Bracket bolts
- Turn the jack bolt to raise or lower

When apron to bed is parallel & level:

- Tighten the jack bolt jam nut(s)
- Tighten Apron to Bracket bolts

Test the adjustments, use test strips of metal, each approximately 3 inches by 3 inches, of the thickness being formed.

Over-bending -- Check end-to-end alignment by clamping two test strips in the brake, about 3 or 4 inches away from either end of the brake. Bend to about 90 degrees, and see if they appear to be bent to the same degree. Remove them from the brake and stack one inside the other. Compare the sharpness of the radius. If one test strip is over-bent or has a sharper radius, slightly move the end of the clamp head which that strip came from. The clamp assembly should be moved back on the end where the over-bending occurs by slightly unclamping the clamp handle, loosening the bracket lock screw and turning the adjusting bracket screw. When the correction is made, retighten the bracket lock screw.

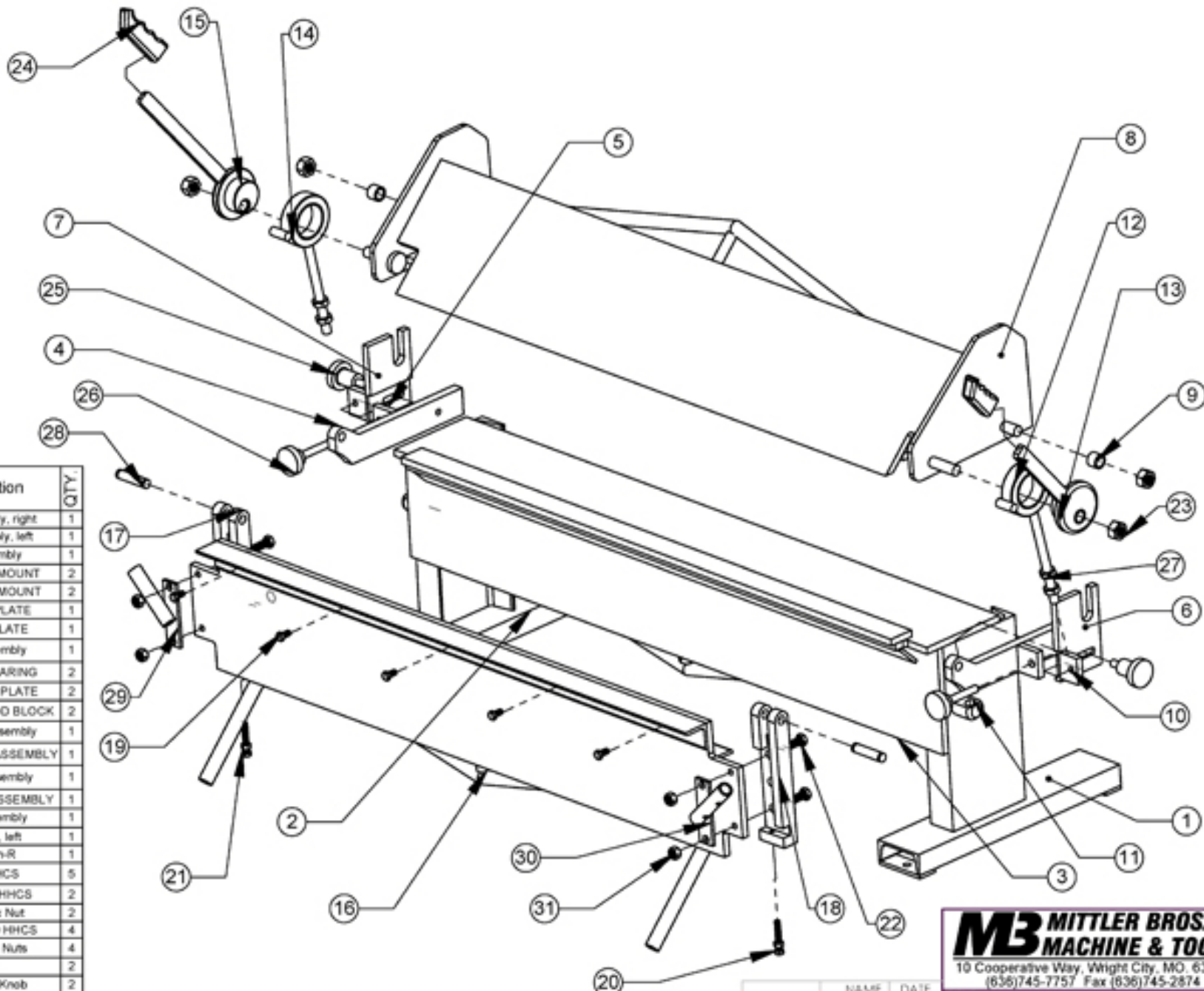

ITEM NO.	PART NUMBER	Description	QTY.
1	2800-4816S-A01-R	Leg Assembly, right	1
2	2800-4816S-A01-L	Leg Assembly, left	1
3	2800-4816S-A02	Bed Assembly	1
4	2800-004	PIVOT ARM MOUNT	2
5	2800-4816S-009	ADJUSTING MOUNT	2
6	2800-005	RT. SLOT PLATE	1
7	2800-006	LF SLOT PLATE	1
8	2800-4816S-A03	Pinch Assembly	1
9	2800-506	BRONZE BEARING	2
10	2800-008	ADJUSTING PLATE	2
11	2800-115	THREADED ROD BLOCK	2
12	2800-A70-R	right pivot assembly	1
13	2800-A75-R	RIGHT LEVER ASSEMBLY	1
14	2800-A70-L	left pivot assembly	1
15	2800-A75-L	LEFT LEVER ASSEMBLY	1
16	2800-4816S-A04	Apron Assembly	1
17	2800-4816S-107-L	Pivot Arm, left	1
18	2800-4816S-107-R	Pivot Arm-R	1
19	91286A623	3/8-16 HHCS	5
20	92620A633	3/8-16x2.25 HHCS	2
21	93827A225	3/8-16 Hex Nut	2
22	91286A319	1/2-13x1.000 HHCS	4
23	93827A299	3/4-10 Hex Nuts	4
24	2800-504	Grip	2
25	2800-016	Tightening Knob	2
26	2800-015	Adjusting Knob	2
27	0.313	5/8" Hex Jam Nut	4
28	2800-104	PIVOT PIN	2
29	2800-4816S-108L	Counter Weight Rod Holder-L	1
30	2800-4816S-108R	Counter Weight Rod Holder-R	1
31	94804A340	1/2-13 Hex Nuts	4

DRAWN	NAME	DATE
	H/J	7/5/12

PROPRIETARY AND CONFIDENTIAL
 THE INFORMATION CONTAINED IN THIS DRAWING IS THE SOLE PROPERTY OF MITTLER BROS. MACHINE & TOOL. ANY REPRODUCTION IN PART OR AS A WHOLE WITHOUT THE WRITTEN PERMISSION OF MITTLER BROS. MACHINE & TOOL IS PROHIBITED.

M3 MITTLER BROS. MACHINE & TOOL
 10 Cooperative Way, Wright City, MO. 63390
 (636)745-7757 Fax (636)745-2874

TITLE: **4816S Assembly**

SIZE	DWG. NO.	REV
A	2800-4816S-A00	

SCALE: 1:10 WEIGHT: 551.88# SHEET 1 OF 1

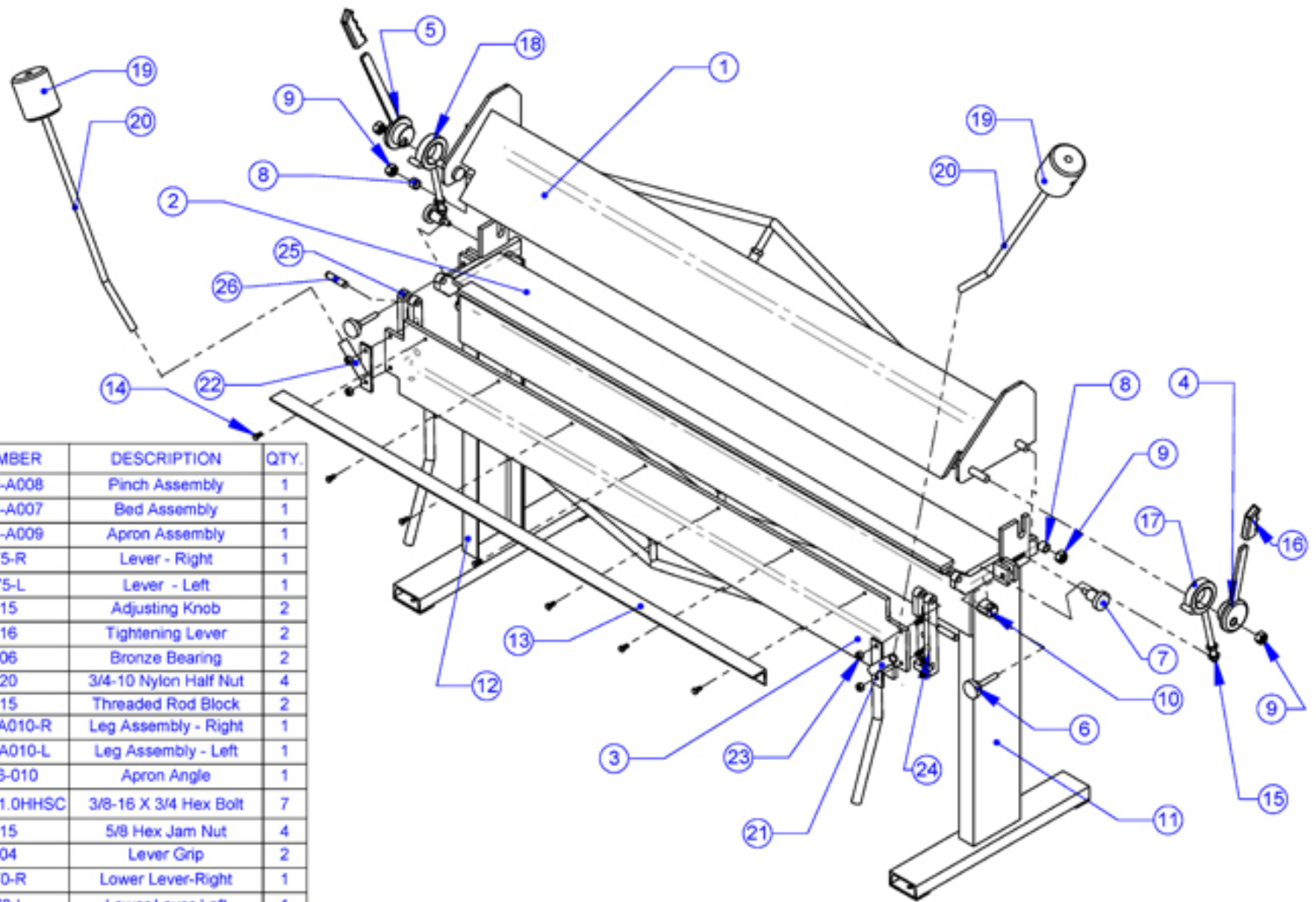

ITEM NO.	PART NUMBER	DESCRIPTION	QTY.
1	2800-7216-A008	Pinch Assembly	1
2	2800-7216-A007	Bed Assembly	1
3	2800-7216-A009	Apron Assembly	1
4	2800-A75-R	Lever - Right	1
5	2800-A75-L	Lever - Left	1
6	2800-015	Adjusting Knob	2
7	2800-016	Tightening Lever	2
8	2800-506	Bronze Bearing	2
9	2800-520	3/4-10 Nylon Half Nut	4
10	2800-115	Threaded Rod Block	2
11	2800-7216-A010-R	Leg Assembly - Right	1
12	2800-7216-A010-L	Leg Assembly - Left	1
13	2800-7216-010	Apron Angle	1
14	750-375-16X1.0HHSC	3/8-16 X 3/4 Hex Bolt	7
15	2800-515	5/8 Hex Jam Nut	4
16	2800-504	Lever Grip	2
17	2800-A70-R	Lower Lever-Right	1
18	2800-A70-L	Lower Lever-Left	1
19	2800-251	Counterweight	2
20	2800-252	Counterweight Rod	2
21	2800-7216-522-R	Counterweight Bracket-R	1
22	2800-7216-522-L	Counterweight Bracket-L	1
23	2800-514	1/2-13 Nyloc Jam Nut	4
24	2800-7216-099-R	Pivot Arm R	1
25	2800-7216-099-L	Pivot Arm L	1
26	2800-104	Pivot Pin	2

**MB MITTLER BROS.
MACHINE & TOOL**
10 Cooperative Way, Wight City, MO. 63390
(636)745-7757 Fax (636)745-2874

NJF 5/30/2012

TITLE:
72" 16 Ga Brake

PROPRIETARY AND CONFIDENTIAL
THE INFORMATION CONTAINED IN THIS
DRAWING IS THE SOLE PROPERTY OF
MITTLER BROS. MACHINE & TOOL. ANY
REPRODUCTION IN PART OR AS A WHOLE
WITHOUT THE WRITTEN PERMISSION OF
MITTLER BROS. MACHINE & TOOL IS
PROHIBITED.

SIZE DWG. NO. REV
A 2800-7216-A00

SCALE: 1:15.5 WEIGHT: 834.146 SHEET 1 OF 1

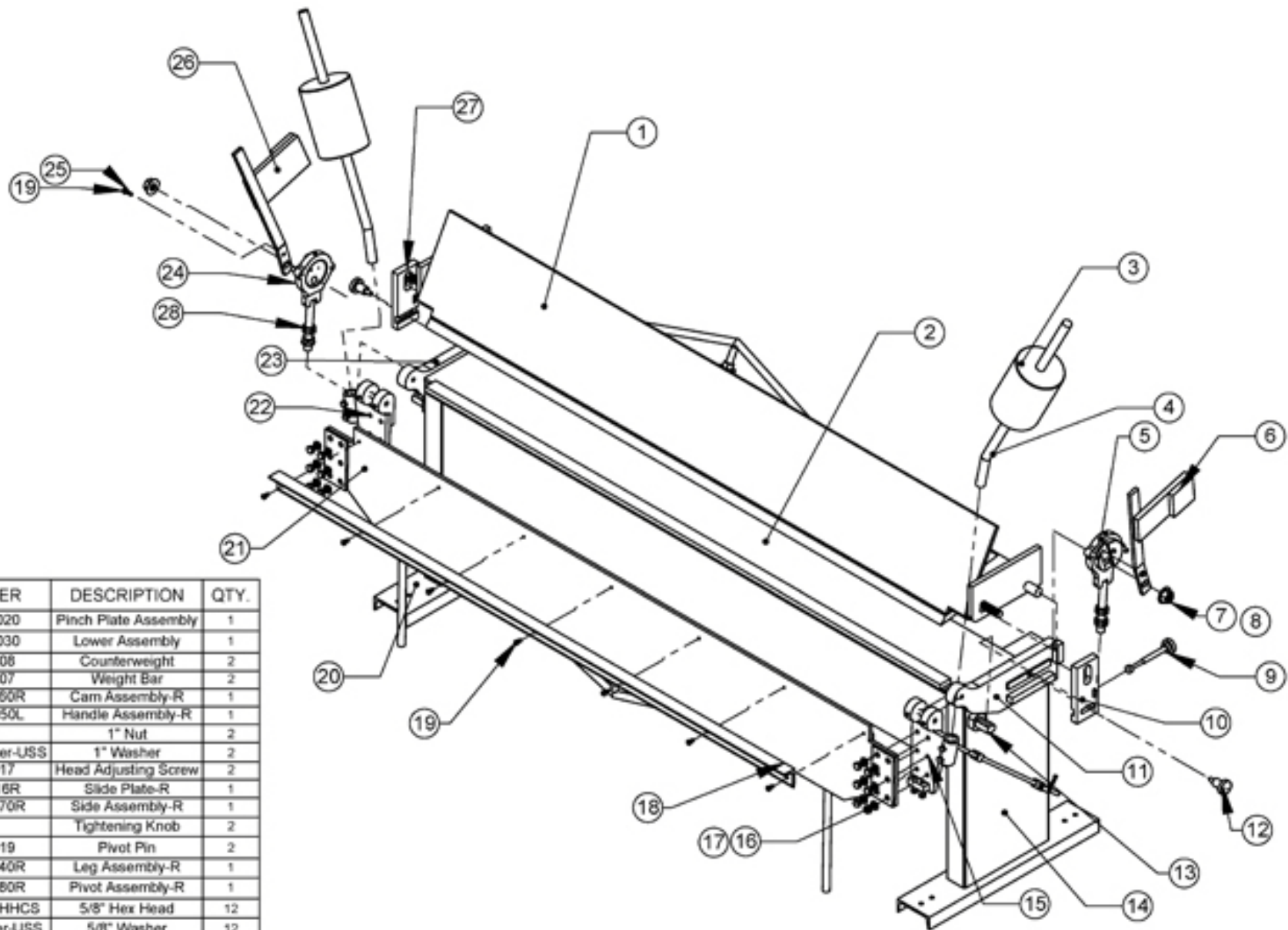

ITEM NO.	PART NUMBER	DESCRIPTION	QTY.
1	2800-9616S-A020	Pinch Plate Assembly	1
2	2800-9616S-A030	Lower Assembly	1
3	2800-9616S-108	Counterweight	2
4	2800-9616S-107	Weight Bar	2
5	2800-9616S-A060R	Cam Assembly-R	1
6	2800-9616S-A050L	Handle Assembly-R	1
7	1-8 HexNut	1" Nut	2
8	750-1.000Flatwasher-USS	1" Washer	2
9	2800-9616S-017	Head Adjusting Screw	2
10	2800-9616S-016R	Slide Plate-R	1
11	2800-9616S-A070R	Side Assembly-R	1
12	2800-016	Tightening Knob	2
13	2800-9616S-019	Pivot Pin	2
14	2800-9616S-A040R	Leg Assembly-R	1
15	2800-9616S-A080R	Pivot Assembly-R	1
16	750-.625-11X1.50HHCS	5/8" Hex Head	12
17	750-.625Flatwasher-USS	5/8" Washer	12
18	2800-9616S-101	Apron Angle	1
19	750-.375-16X1.000HHCS	3/8" Hex Bolts	9
20	2800-9616S-A040L	Leg Assembly-L	1
21	2800-9616S-A010	Apron Assembly	1
22	2800-9616S-A080L	Pivot Assembly-L	1
23	2800-9616S-A070L	Side Assembly-L	1
24	2800-9616S-A060L	Cam Assembly-L	1
25	750-.375Flatwasher-USS	3/8" Washer	2
26	2800-9616S-A050R	Handle Assembly-L	1
27	2800-9616S-016L	Slide Plate-L	1
28	1-8 Slim Hex Nut	1" Nut	8

NJF 6/4/12

PROPRIETARY AND CONFIDENTIAL
 THE INFORMATION CONTAINED IN THIS DRAWING IS THE SOLE PROPERTY OF MITTLER BROS. MACHINE & TOOL. ANY REPRODUCTION IN PART OR AS A WHOLE WITHOUT THE WRITTEN PERMISSION OF MITTLER BROS. MACHINE & TOOL IS PROHIBITED.

MB MITTLER BROS. MACHINE & TOOL
 10 Cooperative Way, Wight City, MO. 63390
 (636)745-7757 Fax (636)745-2874

TITLE: 9616S Assembly

SIZE DWG. NO. REV
A 2800-9616S-A00

SCALE: 1:20 WEIGHT: 1966.787 SHEET 1 OF 1

ITEM NO.	PART NUMBER	Description	Qty.
1	2800-7222S-A030	Bed Assembly	1
2	2800-7222S-A040R	Stand Legs Assembly-R	1
3	2800-7222S-A040L	Stand Legs Assembly-L	1
4	2800-7222S-A020	Pinch Plate Assembly	1
5	2800-7222S-A010	Apron Assembly	1
6	2800-A75-R	RIGHT LEVER ASSEMBLY	1
7	2800-115	THREADED ROD BLOCK	2
8	2800-A70-R	right pivot assembly	1
9	2800-A70-L	left pivot assembly	1
10	2800-A75-L	LEFT LEVER ASSEMBLY	1
11	2800-7222S-A80-L	Adjustment Plate-L	1
12	2800-7222S-048	Angle Brace	2
13	2800-A310-72	Radius Bar Assembly *Optional*	1
14	2800-A60-L	Slide Mount LF	1
15	2800-A60-R	Slide Mount RT	1
16	2800-506	BRONZE BEARING	2
17	750-.750Flatwasher-Uss	3/4" Flat Washer	2
18	2800-515	5/8" Hex Jam Nut	4
19	2800-520	3/4 - 10 nylon half nut	4
20	2800-504 Grp	Grip	2
21	2800-015	Adjusting Knob	2
22	2800-7222S-A80-R	Adjustment Plate-R	1
23	NLN-500C-THIN	NYLON INSERT LOCKNUT, 1/2-13 UNC, THIN	2
24	2800-016	Tightening Knob	2
25	0.5x2-N	SH SHOULDER SCREW	2
26	750-.500Flatwasher-Uss	1/2" Flat Washer	2
27	750-.375-16X.750SHCS	3/8-16x3/4 SHCS	4
28	2800-7222S-012	Apron Angle	1
29	750-.375-16X.625SHCS	3/8-16x5/8 SHCS	7
30	750-.375Lockwasher	3/8" Lock Washer	7
31	750-.3125Flatwasher-Uss	5/16" Flat Washer	4
32	750-.3125-18X1SHCS	5/16-18x1 SHCS	4
33	750-.3125-18Hexnut	5/16-18 Hex Nut	2

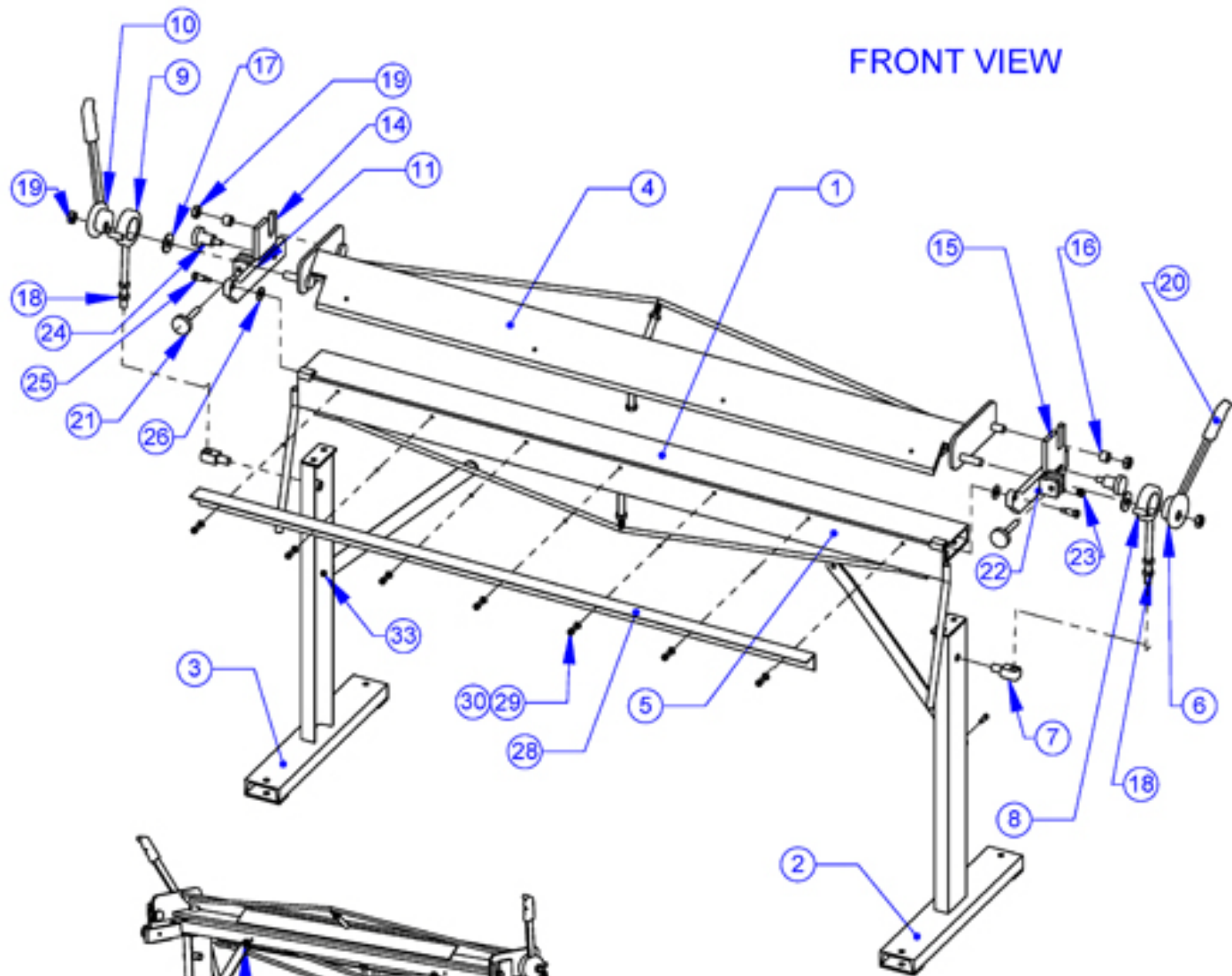

FRONT VIEW

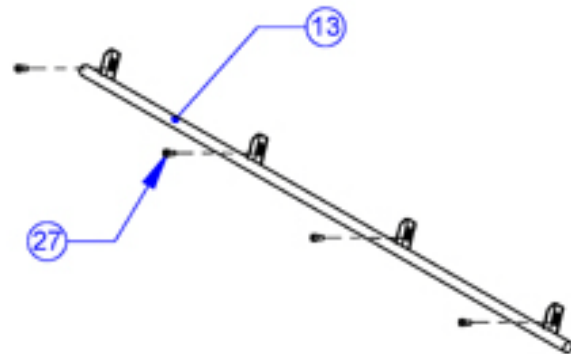

Radius Bar Assembly
Optional

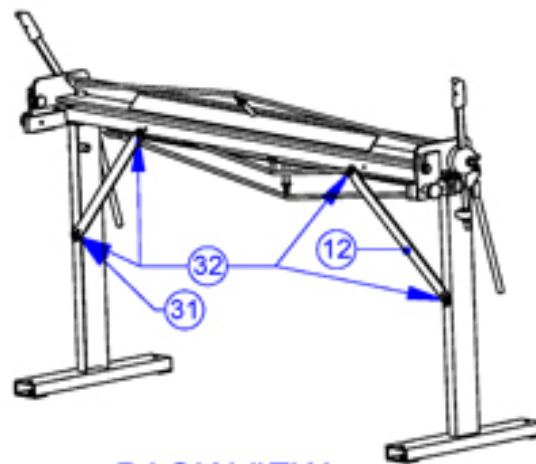

BACK VIEW
Scale 1:26

NJF	5/31/2012
PROPRIETARY AND CONFIDENTIAL THE INFORMATION CONTAINED IN THIS DRAWING IS THE SOLE PROPERTY OF MITTLER BROS. MACHINE & TOOL. ANY REPRODUCTION IN PART OR AS A WHOLE WITHOUT THE WRITTEN PERMISSION OF MITTLER BROS. MACHINE & TOOL IS PROHIBITED.	

**M3 MITTLER BROS.
MACHINE & TOOL**
 10 Cooperative Way, Wright City, MO. 63390
 (636)745-7757 Fax (636)745-2874

TITLE: 7222S Assembly		
SIZE A	DWG. NO. 2800-7222S-A00	REV
SCALE: 1:18	WEIGHT: 292.034	SHEET 1 OF 1

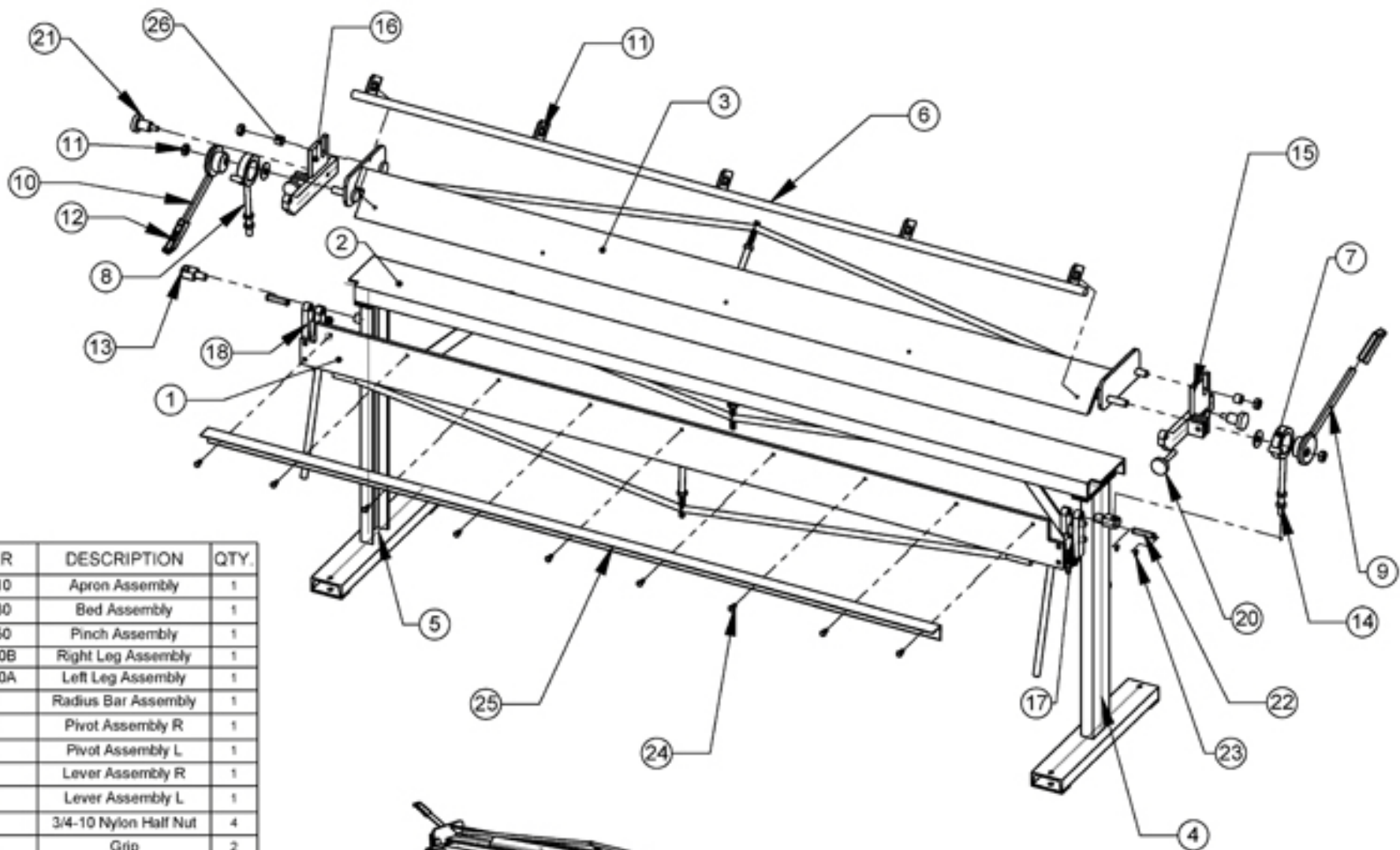

ITEM NO	PART NUMBER	DESCRIPTION	QTY.
1	2800-9622S-A010	Apron Assembly	1
2	2800-9622S-A030	Bed Assembly	1
3	2800-9622S-A050	Pinch Assembly	1
4	2800-9622S-A040B	Right Leg Assembly	1
5	2800-9622S-A040A	Left Leg Assembly	1
6	2800-A310-96	Radius Bar Assembly	1
7	2800-A70-R	Pivot Assembly R	1
8	2800-A70-L	Pivot Assembly L	1
9	2800-A75-R	Lever Assembly R	1
10	2800-A75-L	Lever Assembly L	1
11	2800-520	3/4-10 Nylon Half Nut	4
12	2800-504	Grip	2
13	2800-115	Threaded Rod Block	2
14	2800-515	5/8 Hex Jam Nut	4
15	2800-A60-R	Slide Mount R	1
16	2800-A60-L	Slide Mount L	1
17	2800-9622S-A130R	Apron Pivot Assembly R	1
18	2800-9622S-A130L	Apron Pivot Assembly L	1
19	2800-7222S-048	Angle Brace	2
20	2800-015	Adjusting Knob	2
21	2800-016	Tightening Knob	2
22	2800-104	Pivot Pin	2
23	1/2 Retaining Ring	1/2 Retaining Ring	4
24	750-.375-16X-.750HHCS	3/8"-16 Hex Bolts	14
25	2800-9622S-012	Apron Angle	1
26	2800-506	Bronze Bearing	2

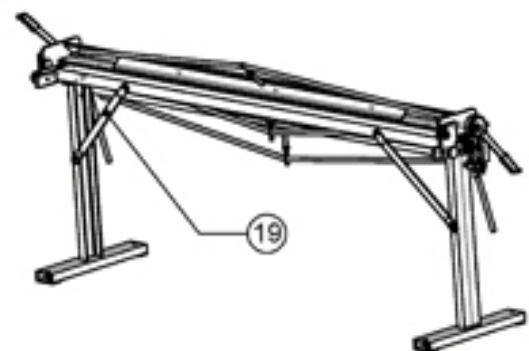

BACK VIEW
SCALE 1:35

NUT 6/7/12
PROPRIETARY AND CONFIDENTIAL
 THE INFORMATION CONTAINED IN THIS DRAWING IS THE SOLE PROPERTY OF MITTLER BROS. MACHINE & TOOL. ANY REPRODUCTION IN PART OR AS A WHOLE WITHOUT THE WRITTEN PERMISSION OF MITTLER BROS. MACHINE & TOOL IS PROHIBITED.

M3 MITTLER BROS. MACHINE & TOOL
 10 Cooperative Way, Wright City, MO, 63390
 (636)745-7757 Fax (636)745-2874

TITLE: **9622S Assembly**

SIZE A	DWG. NO. 2800-9622S-A00	REV
SCALE: 1:18	WEIGHT: 465.646	SHEET 1 OF 1

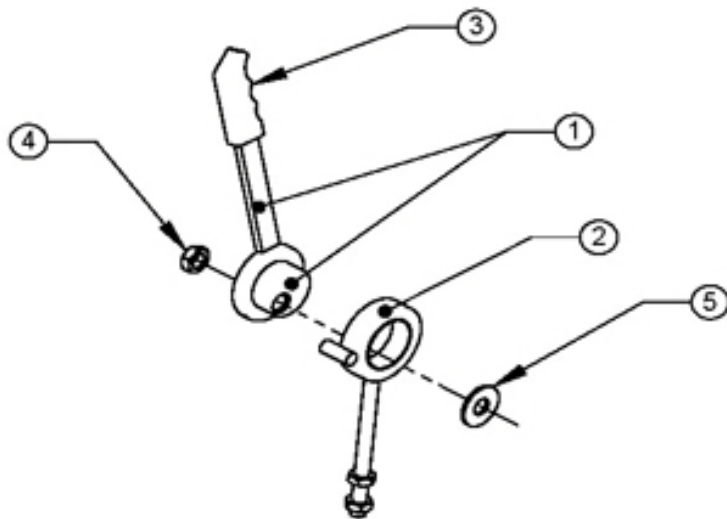

Left Lever Assembly
2800-A41-L

LEFT LEVER ASSEMBLY			
ITEM NO.	PART NUMBER	DESCRIPTION	QTY.
1	2800-A42-L	Upper Cam Lever Assembly - Left	1
2	2800-A43-L	Cam Ring Threaded Assembly - Left	1
3	2800-504	Grip	1
4	2800-520	3/4-10 Nylon Half Nut	1
5	3/4"	Narrow Flat Washer	1

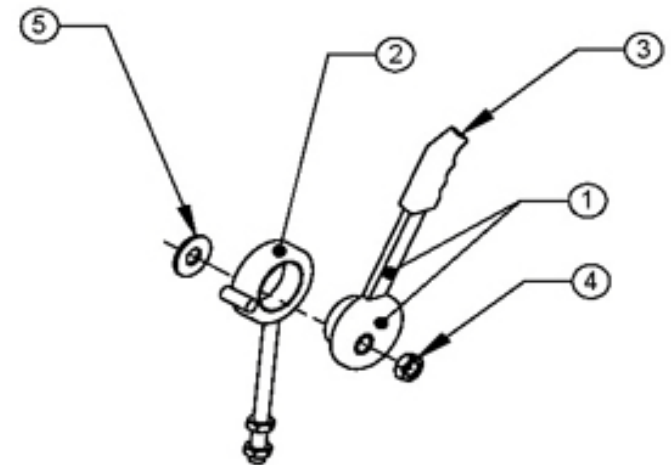

Right Lever Assembly
2800-A41-R

RIGHT LEVER ASSEMBLY			
ITEM NO.	PART NUMBER	DESCRIPTION	QTY.
1	2800-A42-R	Upper Cam Lever Assembly - Right	1
2	2800-A43-R	Cam Ring Threaded Assembly - Right	1
3	2800-504	Grip	1
4	2800-520	3/4-10 Nylon Half Nut	1
5	3/4"	Narrow Flat Washer	1

**MB MITTLER BROS.
MACHINE & TOOL**
10 Cooperative Way, Wright City, MO 63390
(636)745-7757 Fax (636)745-2874

4/1/2010

PROPRIETARY AND CONFIDENTIAL
THE INFORMATION CONTAINED IN THIS
DRAWING IS THE SOLE PROPERTY OF
MITTLER BROS. MACHINE & TOOL. ANY
REPRODUCTION IN PART OR AS A WHOLE
WITHOUT THE WRITTEN PERMISSION OF
MITTLER BROS. MACHINE & TOOL IS
PROHIBITED.

TITLE:
Lever Assemblies

SEE DWG. NO.	REV
A	2800-A41 E.V
SCALE: 1:8	WEIGHT: 472.215 SHEET 1 OF 1

5

4

3

2

1

CAUTION: Read and Understand

These Operating, Servicing, and
Safety Instructions, Before Using
This Machine.

1-800-467-2464

10 Cooperative Way Wright City, MO 63390

P.O. Box 110 Foristell, MO 63348

1-636-745-7757 Fax 1-636-745-2874

www.mittlerbros.com