

*Attaches to bottom of gear rack

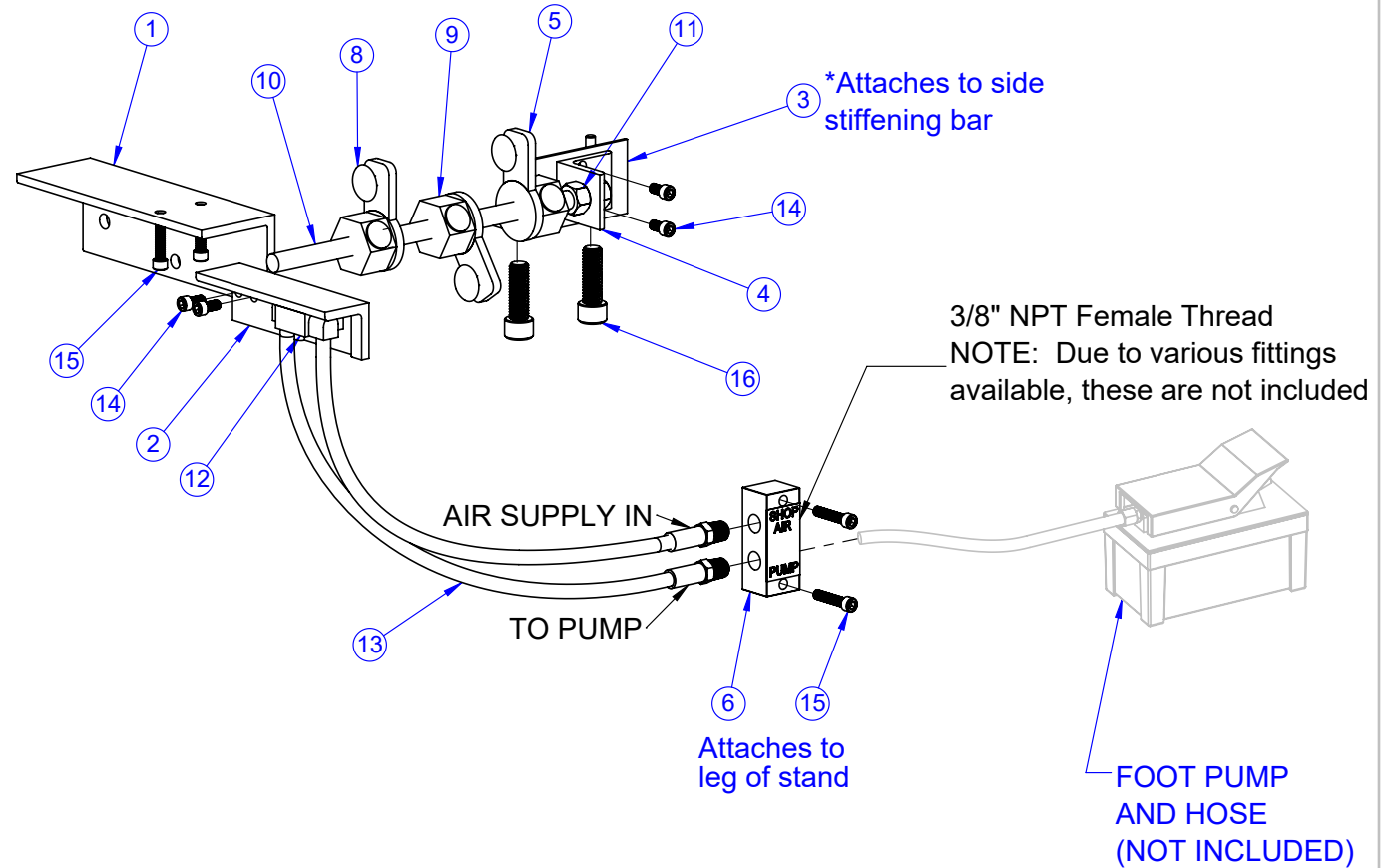

3/8" NPT Female Thread
NOTE: Due to various fittings available, these are not included

FOOT PUMP AND HOSE (NOT INCLUDED)

ITEM NO.	PART NUMBER	Description	QTY.
1	2500-160	Spring Bracket *Standard on machines after 8/2010	1
2	2500-161	Switch Bracket	1
3	2500-162	Stop Adjustment Bracket Mount *Standard on machines after 8/2010	1
4	2500-163	Stop Adjustment Bracket	1
5	2500-164	Arm	3
6	2500-165	Manifold	1
7	2500-521	Brass Pipe Elbow	2
8	2500-523	Elevator Bolt	3
9	2500-524	Button Thread Collar Nut	3
10	2500-525	1/2"-13 x 11" Threaded Rod	1
11	.500" Hex Nut	1/2" Hex Nut	2
12	2500-522	Air Valve	1
13	Air Hose	18" Air Hose	2
14	91251A537	1/4"-20 x 1/2" SHCS	4
15	91251A544	1/4"-20 x 1-1/4" SHCS	4
16	91251A716	1/2"-13 x 1-1/2" SHCS	2

***Note:**
If purchased before 8/2010,
Items 1, 3, 16, 17 are required.

If purchased after 8/2010,
Items 1, 3, 16, 17 are
standard on machine.

PROPRIETARY AND CONFIDENTIAL		NAME	DATE
THE INFORMATION CONTAINED IN THIS DRAWING IS THE SOLE PROPERTY OF MITTLER BROS. MACHINE & TOOL. ANY REPRODUCTION IN PART OR AS A WHOLE WITHOUT THE WRITTEN PERMISSION OF MITTLER BROS. MACHINE & TOOL IS PROHIBITED.		MSA	2/4/20
UNLESS OTHERWISE SPECIFIED:		DIMENSIONS ARE IN INCHES	
QUANTITY		TOLERANCES:	
MATERIAL		FRACTIONAL ±1/32	
FINISH		ONE PLACE DECIMAL ±.015	
DO NOT SCALE DRAWING		TWO PLACE DECIMAL ±.010	
		THREE PLACE DECIMAL ±.005	
		ANGULAR ±1°	
COMMENTS:		TITLE:	
		Air Stop Kit	
SIZE	DWG. NO.	REV	
A	2500-400		
SCALE: 1:5	WEIGHT: 8.253	SHEET 1 OF 1	