

ITEM NO.	PART NUMBER	Description	QTY.
1	2500-004	Main Base Plate	1
2	2500-014	Square Drive Shaft	1
3	2500-510	2 Pt. Gear	1
4	2500-010	Hyd. Cylinder Mounting Block	1
5	2500-012	Bottom Support Plate	1
6	2500-013-R	Stiffening Bars	1
7	2500-013-L	Stiffening Bars	1
8	2500-015	Gear Rack Support Block	1
9	2500-506	Lamia, 3/8 x 2 x 48	1
10	2500-504	Gear Rack	1
11	2500-003	Spring Return Bracket	1
12	2500-509	Square Shaft Flange Bearing	2
13	2500-505	Rack Return Spring	2
14	2500-519	Hyd. Cylinder - C258C	1
15	2500-514	Hydraulic Ram Modified	1
16	2500-160	Spring Bracket	1
17	2500-011-1	Shoe Spacer	3
18	2500-016	Square Shaft Key	2
19	2500-123	Stop Valve Mount	1
20	2500-508	Square Shaft Bearing	1
21	2500-511	Square Shaft Thrust Washer	1
22	750-FHCS-10-32X0.375	FHCS 10-32 x 3/8"	3

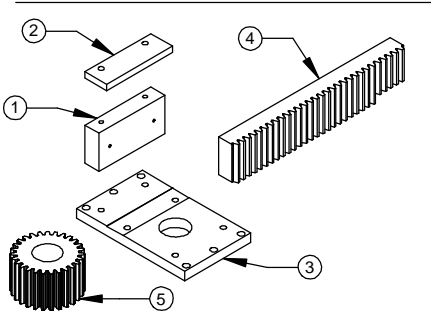

ITEM NO.	PART NUMBER	DESCRIPTION	QTY.
1	2500-015 HD	Gear Rack Support Block	1
2	GEAR PLATE HD	Top Gear Rack Plate	1
3	2500-012 HD	Bottom Support Plate	1
4	2500-504 HD	Gear Rack	1
5	2500-510 HD	2 Pt. Gear	1

NOTE:
 HD PARTS
 REPLACE: 2500-504, 2500-015
 2500-510, 2500-012 & ADD
 TOP GEAR RACK PLATE

PROPRIETARY AND CONFIDENTIAL
 THE INFORMATION CONTAINED IN THIS
 DRAWING IS THE SOLE PROPERTY OF
 MITTLER BROS. MACHINE & TOOL. ANY
 REPRODUCTION IN PART OR AS A WHOLE
 WITHOUT THE WRITTEN PERMISSION OF
 MITTLER BROS. MACHINE & TOOL IS
 PROHIBITED.

Ram/Table Assembly
 11/2011 - Present

3/10/2011		UNLESS OTHERWISE SPECIFIED: DIMENSIONS ARE IN INCHES	NAME	DATE	 10 Cooperative Way, Wright City MO, 63390 (636)745-7757 Fax (636)745-2874
4/5/2011		TOLERANCES:	DRWN	5/15/08	
11/2/2011		FRACTIONAL ±.015	CHECKED		
		ONE PLACE DECIMAL ±.015	ENG APPR.		
		TWO PLACE DECIMAL ±.010	MFG APPR.		TITLE: Ram/Table Assembly
		THREE PLACE DECIMAL ±.005	Q.A.		SIZE DWG. NO. REV B 2500-170A
		ANGULAR ± 1°			SCALE: 1:8 WEIGHT: SHEET 1 OF 1
		QUANTITY 1			
		MATERIAL	FINISH	LENGTH	
		NEXT ASSY	USED ON	FINISH	COMMENTS
		APPLICATION	DO NOT SCALE DRAWING		