

ITEM NO.	PART NUMBER	DESCRIPTION	QTY.
1	2500-034-02	Digital Mounting Channel	1
2	2500-146	Digital Scale Linkage Rod	1
3	2500-151	Digital Scale Mount	1
4	2500-024	Mnt Pcs for Digital Scale	2
5	2500-025-02	Lexan Guard	1
6	2500-503	Digital Scale	1

Note:
This Digital Scale Assembly was
used from Dec. 2006 to July 2008.

Refer to the chart below for Digital Scale
Assemblies from all time periods.

Time Frame That Digital Scale was Manufactured During	Drawing
2001 - Nov 2006	2500-050-01
Dec 2006 - July 2008	2500-050-02
August 2008 - Present	2500-250-03

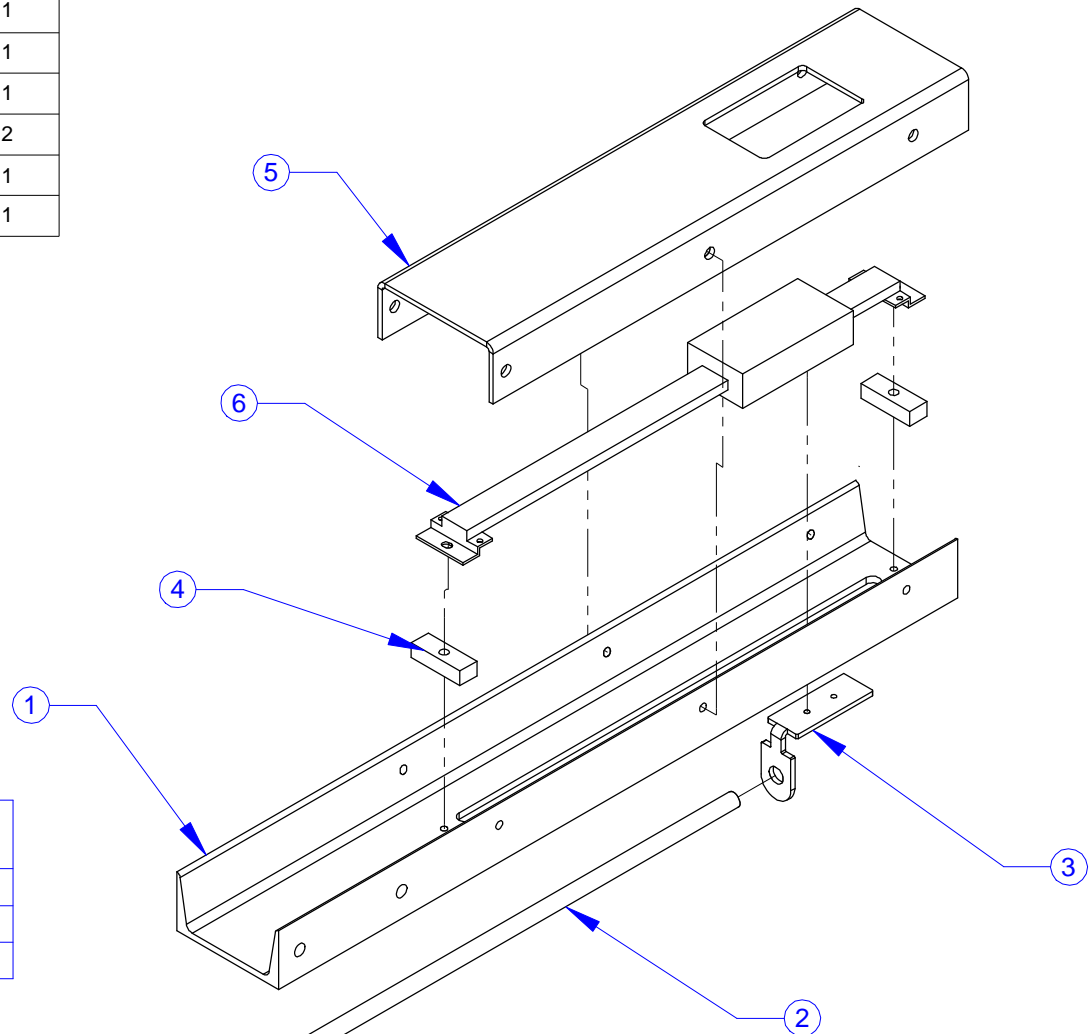

PROPRIETARY AND CONFIDENTIAL
THE INFORMATION CONTAINED IN THIS
DRAWING IS THE SOLE PROPERTY OF
MITTLER BROS. MACHINE & TOOL. ANY
REPRODUCTION IN PART OR AS A WHOLE
WITHOUT THE WRITTEN PERMISSION OF
MITTLER BROS. MACHINE & TOOL IS
PROHIBITED.

		UNLESS OTHERWISE SPECIFIED: DIMENSIONS ARE IN INCHES TOLERANCES: FRACTIONAL ±.015 ONE PLACE DECIMAL ±.015 TWO PLACE DECIMAL ±.010 THREE PLACE DECIMAL ±.005 ANGULAR ±1°		NAME RKH	DATE 5/15/08	MB MITTLER BROS. MACHINE & TOOL 10 Cooperative Way, Wright City, MO. 63390 (636)745-7757 Fax (636)745-2874 TITLE: Digital Scale 12/2006 - 7/2008 SIZE DWG. NO. REV A 2500-050-02
		QUANTITY 1		CHECKED		
		MATERIAL YYYY		ENG APPR.		
		FINISH		MFG APPR.		
NEXT ASSY	USED ON			Q.A.		
APPLICATION		DO NOT SCALE DRAWING		COMMENTS		
						SCALE: 1:4 WEIGHT: 8.619 SHEET 1 OF 1