

ITEM NO.	PART NUMBER	Description	QTY.
1	2500-025-01	Lexan Gaurd	1
2	2500-503	Digital Scale	1
3	2500-021	Gear Rack Cover	1
4	2500-028	Stud Plate	1
5	2500-020	Adjustable Bracket	1
6	2500-024	Mnt Pcs for Digital Scale	2
7	Stud	1/8" Stud	1

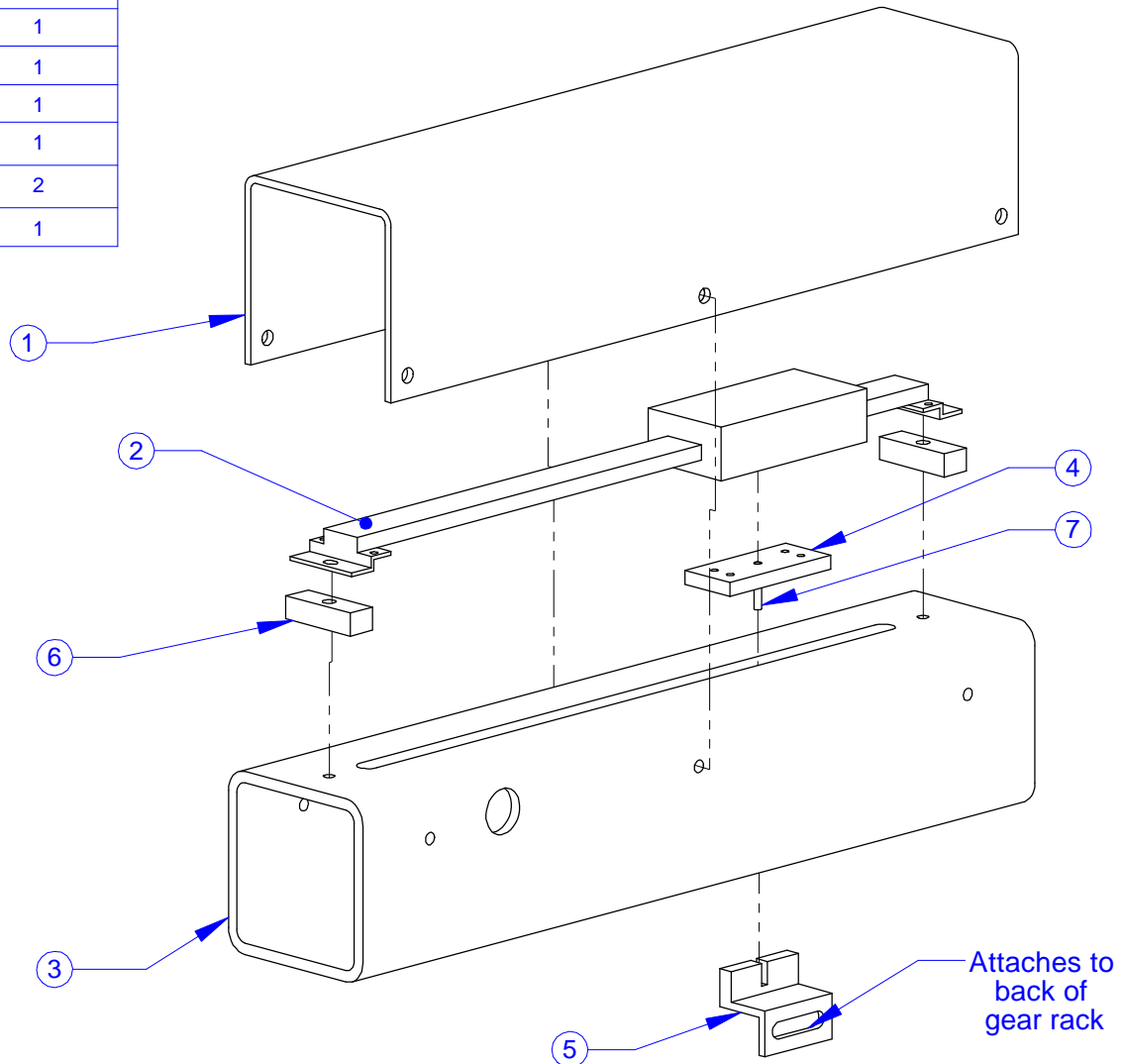

Note:
This Digital Scale Assembly was used from 2001 until Nov. 2006.

Refer to the chart below for Digital Scale Assemblies from all time periods.

Time Frame That Digital Scale was Manufactured During	Drawing
2001 - Nov 2006	2500-050-01
Dec 2006 - July 2008	2500-050-02
August 2008 - Present	2500-250-03

PROPRIETARY AND CONFIDENTIAL
THE INFORMATION CONTAINED IN THIS DRAWING IS THE SOLE PROPERTY OF MITTLER BROS. MACHINE & TOOL. ANY REPRODUCTION IN PART OR AS A WHOLE WITHOUT THE WRITTEN PERMISSION OF MITTLER BROS. MACHINE & TOOL IS PROHIBITED.

		UNLESS OTHERWISE SPECIFIED:		NAME	DATE	M3 MITTLER BROS. MACHINE & TOOL 10 Cooperative Way, Wright City, MO. 63390 (636)745-7757 Fax (636)745-2874	
		DIMENSIONS ARE IN INCHES		DRAWN	BAB		12/2010
		TOLERANCES:		CHECKED			
		FRACTIONAL ±.015		ENG APPR.			
		ONE PLACE DECIMAL ±.015		MFG APPR.			
		TWO PLACE DECIMAL ±.010		Q.A.			
		THREE PLACE DECIMAL ±.005		COMMENTS			
		ANGULAR ±1°					
		QUANTITY				TITLE:	
		MATERIAL				Digital Scale 2001-11/2006	
		FINISH				SIZE DWG. NO. REV	
NEXT ASSY	USED ON					A 2500-050-01	
APPLICATION		DO NOT SCALE DRAWING				SCALE: 1:3 WEIGHT: 7.479 SHEET 1 OF 1	