

BOM Table			
ITEM NO.	PART NUMBER	DESCRIPTION	QTY.
1	2500-001	Acme Screw Mounting Block	1
2	2500-129	Support Rod	1
3	2500-006	Roller Clevis Block	1
4	2500-128	Cam Top Cap	1
5	2500-127	Cam Center Shaft	1
6	2500-513	Oilite Bushing Mod.	1
7	2500-132	Cam Collar	1
8	2500-126	Cam Bottom Cap	1
9	2500-134	1" Spacer	5
10	2500-143	1/4" Spacer	3
11	2500-144	1/8" Spacer	2
12	2500-130	Tension Release Handle	1
13	2500-133	Tension Release Lever	1

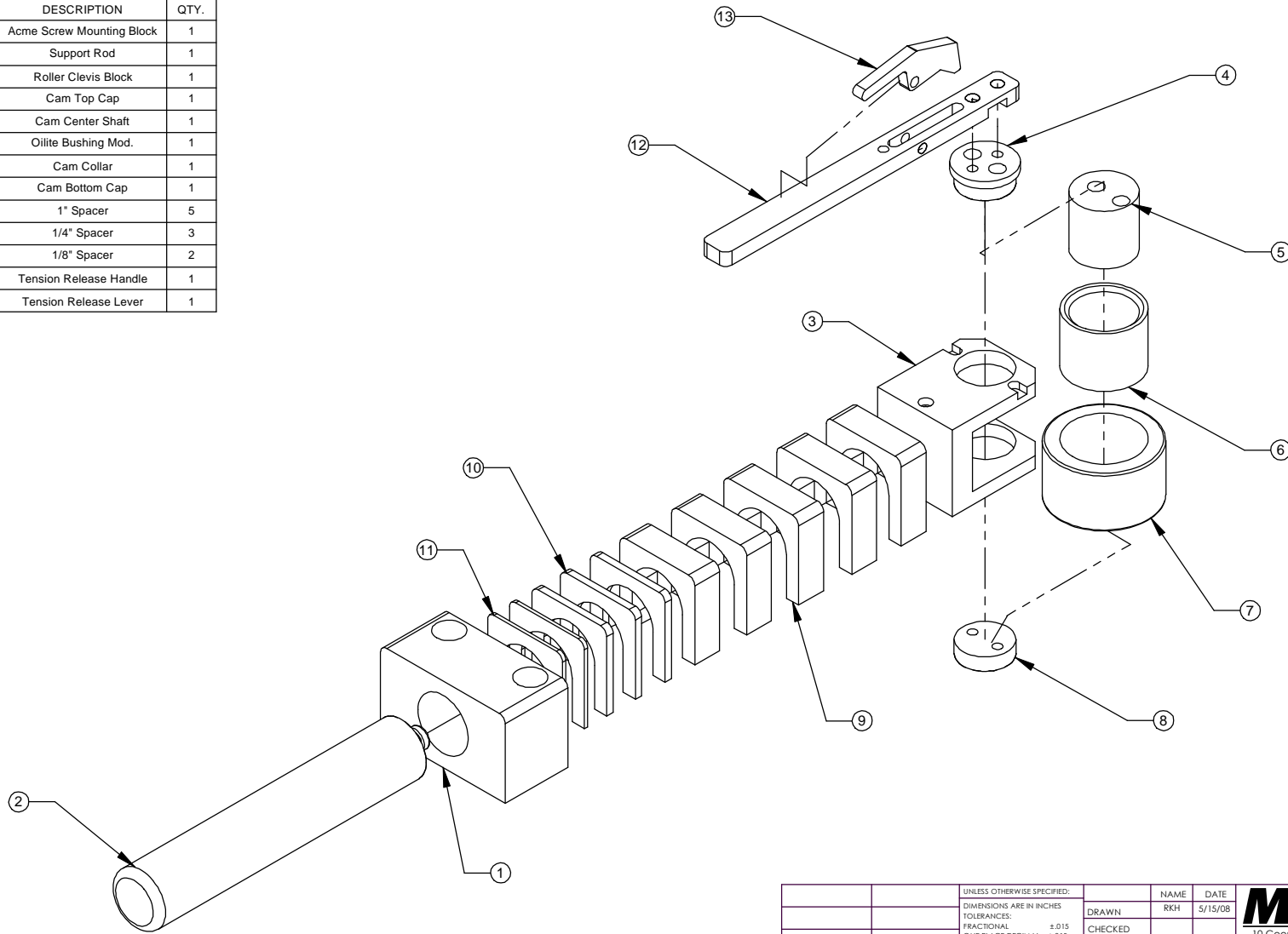

PROPRIETARY AND CONFIDENTIAL
 THE INFORMATION CONTAINED IN THIS
 DRAWING IS THE SOLE PROPERTY OF
 MITTLER BROS. MACHINE & TOOL. ANY
 REPRODUCTION IN PART OR AS A WHOLE
 WITHOUT THE WRITTEN PERMISSION OF
 MITTLER BROS. MACHINE & TOOL IS
 PROHIBITED.

		UNLESS OTHERWISE SPECIFIED:		NAME	DATE
		DIMENSIONS ARE IN INCHES		RRK	5/15/08
		TOLERANCES:			
		FRACTIONAL ±.015		DRAWN	
		ONE PLACE DECIMAL ±.015		CHECKED	
		TWO PLACE DECIMAL ±.010		ENG APPR.	
		THREE PLACE DECIMAL ±.005		MFG APPR.	
		ANGULAR ± 1°		Q.A.	
		QUANTITY	1		
		MATERIAL	Yyyy	FINISH	
				LENGTH	
NEXT ASSY	USED ON	FINISH	COMMENTS		
APPLICATION		DO NOT SCALE DRAWING			

MB MITTLER BROS. MACHINE & TOOL		
10 Cooperative Way, Wright City MO, 63390 (636)745-7757 Fax (636)745-2874		
TITLE: Cam Assembly		
SIZE	DWG. NO.	REV
B	2500-010 Assem	
SCALE: 1:3		WEIGHT: 26.039 SHEET 1 OF 1