

BENCH PRESS LOUVER TOOLING

- 1" LOUVER START UP KIT 2200-LA-01
- 2" LOUVER START UP KIT 2200-LA-02
- 3" LOUVER START UP KIT 2200-LA-03
- 3" DOME LOUVER START UP KIT
2200-LA-06
- 4" LOUVER START UP KIT 2200-LA-04
- 5" LOUVER START UP KIT 2200-LA-05

TOOLING ADAPTER
#2200-021

5/16 x 1.25"
SHOULDER BOLT

UPPER SPRING
STOP #500-008
SIDES WITH SPRING
HOLES MARKED WITH
#1 OR #3
(SEE PAGE 2)

SPRING (3 PCS.)
#500-502

LOWER SPRING
STOP #500-007
SIDES WITH SPRING
HOLES MARKED WITH
#2 OR #4
(SEE PAGE 2)

URETHANE FILLER
1" #500-061
2" #500-062
3" #500-063
4" #500-064
5" #500-065

DIE
1" #500-029
2" #500-023
3" #500-014
4" #500-013
5" #500-012

DIE ADAPTER PLATE
#500-031
REQUIRED ON 1", 2", 3" ONLY

PUNCH

- 1" #500-028
- 2" #200-024
- 3" #500-011
- 3" DOME #500-015
- 4" #500-010
- 5" #500-009

SHEAR PLATE

- 1" #500-030
- 2" #500-027
- 3" #500-016
- 4" #500-006
- 5" #500-006

3/8-16 x 1-1/2" SHCS.
(2 PCS. 5", 4")

1/4-20 x 1-1/4" SHCS.
(2 PCS. 1", 2", 3")

1/4-20 x 1" SHFS.
(2 PCS.)

5/16-18 x 3/4" SHFS.
(4 PCS.)

TOOLING MOUNTING
PLATE #2200-023

3/8-16 x 1" SHCS.
(2 PCS.)

3/8" WASHER
(2 PCS.)

BENCH PRESS LOUVER TOOLING

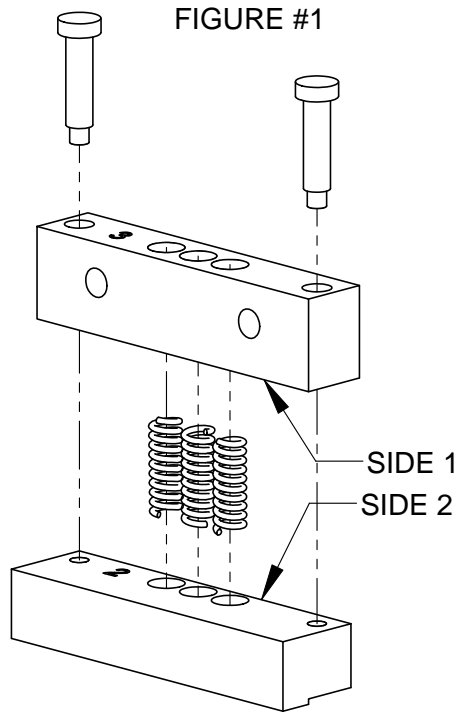

1", 2", 3" ASSEMBLY
MATE SIDE 2 ON THE LOWER SPRING STOP
WITH SIDE 1 ON THE UPPER SPRING STOP

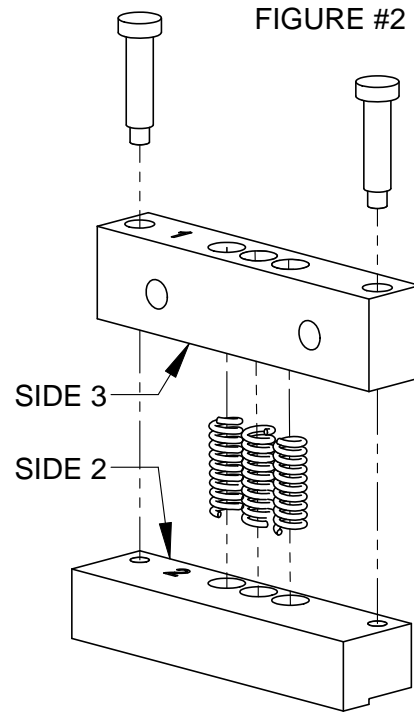

3" DOME ASSEMBLY
MATE SIDE 2 ON THE LOWER SPRING STOP
WITH SIDE 3 ON THE UPPER SPRING STOP

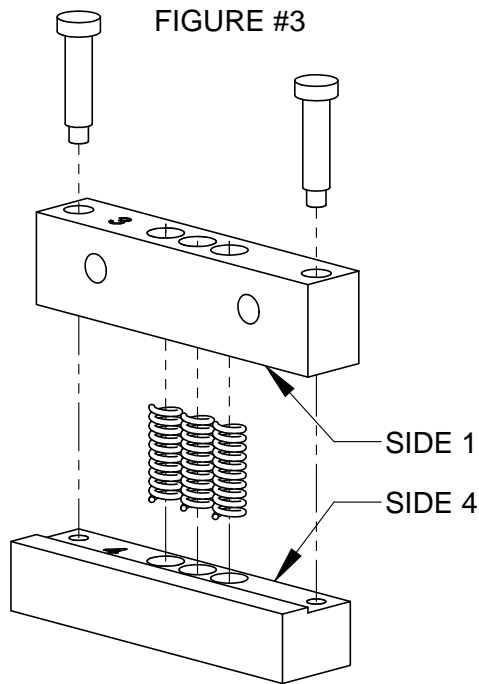

4', 5" TAPER POINT PUNCH ASSEMBLY (INTRODUCED 11/1/2009)
MATE SIDE 4 ON THE LOWER SPRING STOP
WITH SIDE 1 ON THE UPPER SPRING STOP

NOTE: 4", 5" STRAIGHT PUNCH ASSEMBLY (PURCHASED PRIOR TO
11/1/2009) USE FIGURE #1