

# URETHANE STRIPPER INSTRUCTIONS

- 1) Measure from flat to flat as shown. Cut urethane stripper to match
- 2) Push stripper onto punch shank (ID is slightly undersized to grip punch). First stroke of press forces punch tip through stripper bottom.

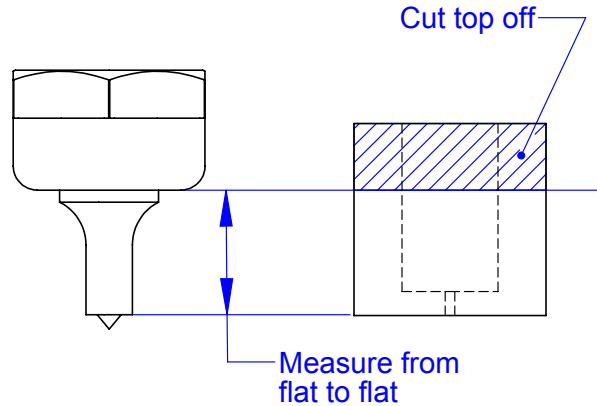

Cut urethane  
stripper  
to match

**STEP 1**

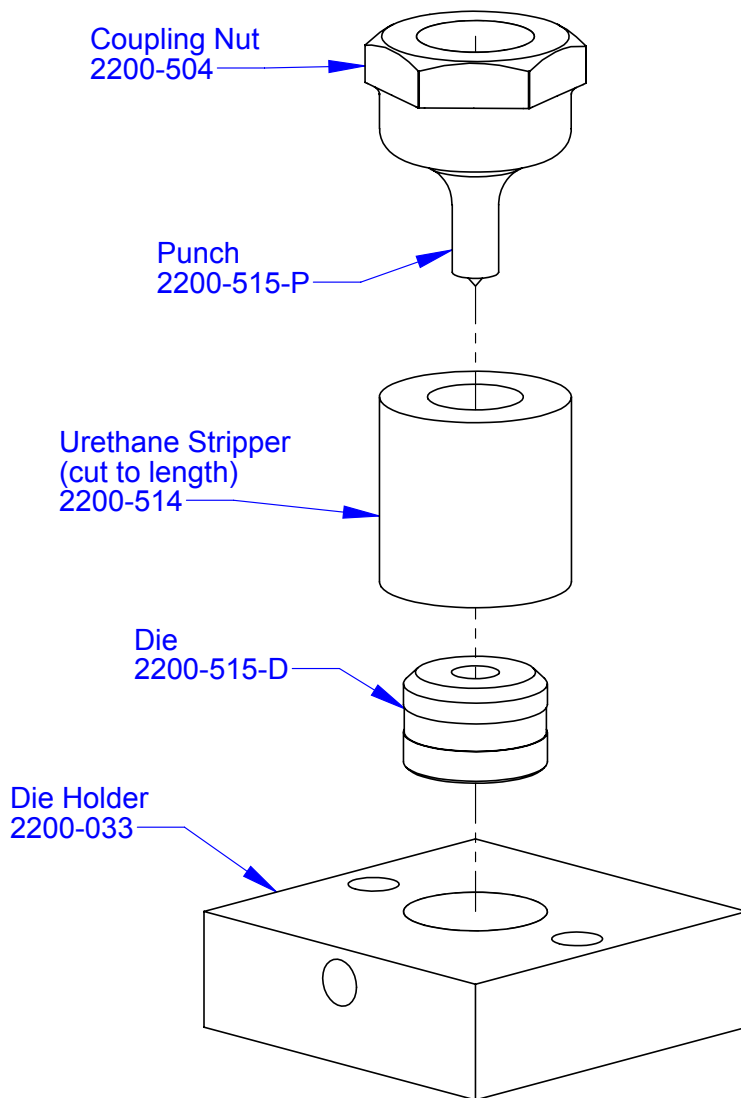

Urethane strippers generate high holding pressure on the blank and strip the blank cleanly from the punch.

The stripper remembers its shape and springs back, hit after hit.

**STEP 2**