

NOTE:  
1/4"-20 x 1" SHCS  
Not Used

**1100-UADJ  
Upgraded Adjustable Vise**

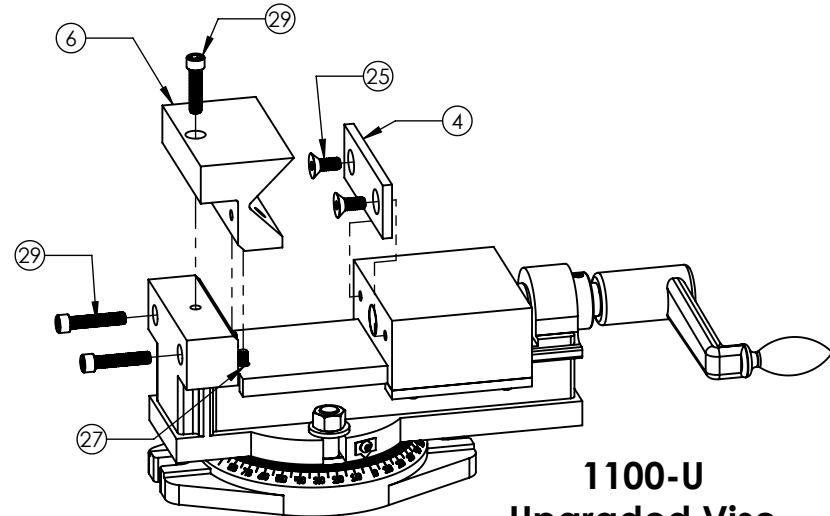

**1100-U  
Upgraded Vise**

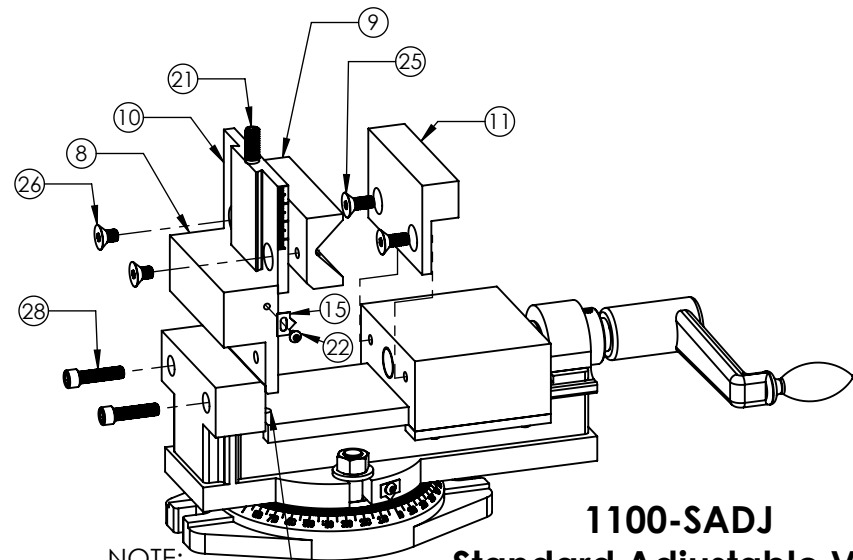

NOTE:  
1/4"-20 x 1" SHCS  
Not Used

**1100-SADJ  
Standard Adjustable Vise**

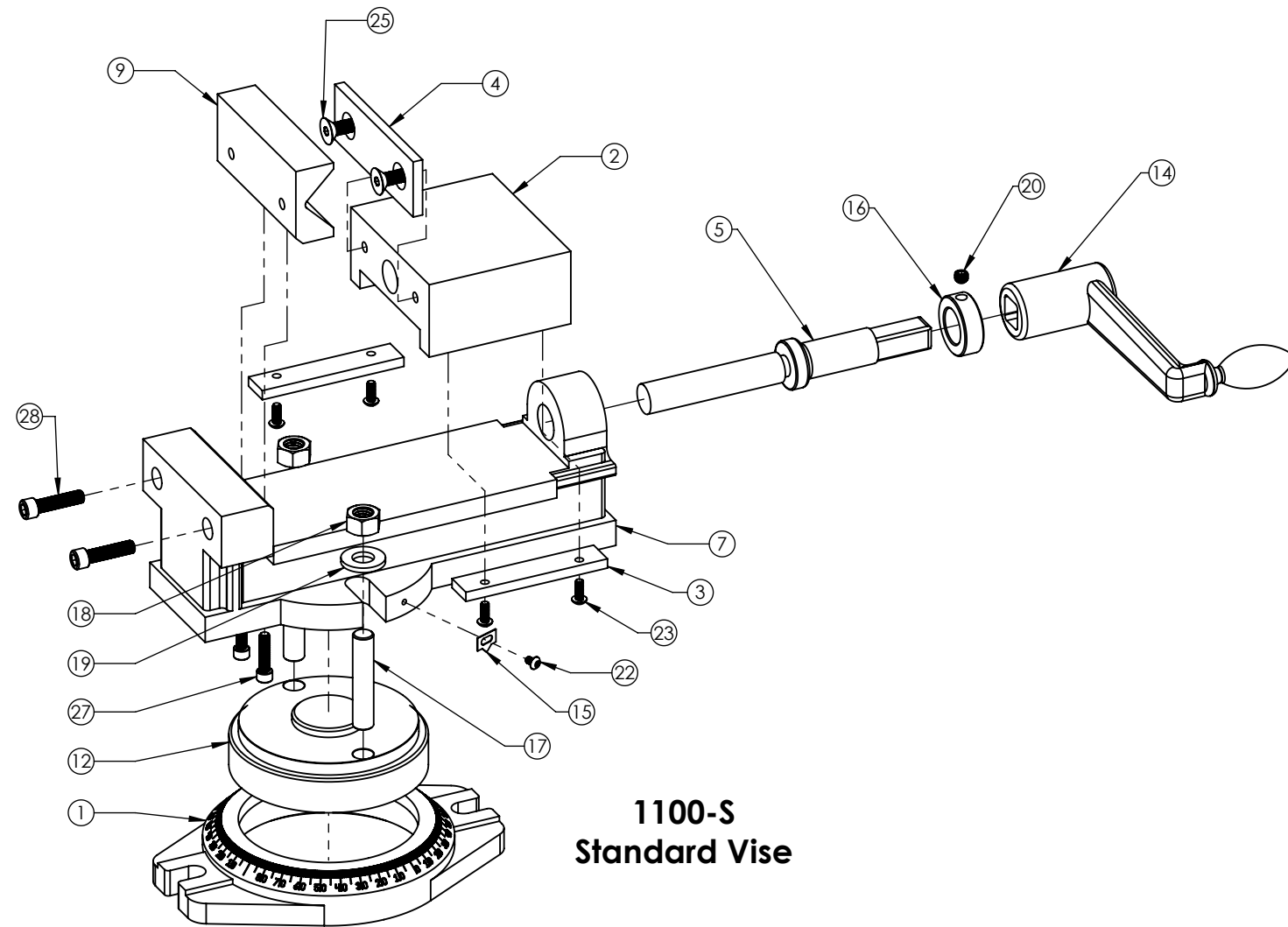

**1100-S  
Standard Vise**

ITEM NO.	PART NUMBER	DESCRIPTION	QTY.
1	1100-001	Swivel Base	1
2	1100-002	Movable Jaw	1
3	1100-004	Vise Runner	2
4	1100-005	Vise Jaw Flat	1
5	1100-006	Vise Screw	1
6	1100-007	2" Pipe; 2-1/2" Tube Jaw (1100-U)	1
7	1100-008	Vise Base	1
8	1100-014	Offset Vise V-Gib Block (1100-SADJ, UADJ)	1
9	1100-015	Std. Vise V Jaw (1100-S, SADJ, UADJ)	1
10	1100-016	Offset Vise V-Gib (1100-SADJ, UADJ)	1
11	1100-017	Offset Vise Backstop	1
12	1100-018	Swivel Base Center Plug	1
13	1100-020	Upgrade Adj. Vise Shim	1
14	1100-501	Vise Handle	1
15	1100-502	Pointer	1
16	400-519	Vise Screw Collar	1
17	400-554	1/2 - 13 x 2 1/2 Stud	2
18	94895A823	1/2"-13 Hex Nut	2
19	90126A033	.531" ID x 1.062" OD Washer	2
20	91375A595	5/16-24 x 1/4" Set Screw	1
21	91375A636	3/8"-16 x 3" Set Screw	1
22	91255A190	#8-32 x 1/4" BHCS	1
23	91255A265	#10-32 x 1/2" BHCS	4
24	91253A540	1/4"-20 x 3/4" FHCS	2
25	91253A581	5/16"-18 x 3/4" FHCS	2
26	91253A331	5/16"-24 x 1/2" FHCS	2
27	4XE35 (GRAINGER)	1/4"-20 x 1" SHCS	2
28	91251A385	5/16"-24 x 1-1/4" SHCS	2
29	91251A387	5/16"-24 x 1-1/2" SHCS	2

**PROPRIETARY AND CONFIDENTIAL**

THE INFORMATION CONTAINED IN THIS DRAWING IS THE SOLE PROPERTY OF MITTLER BROS. MACHINE & TOOL. ANY REPRODUCTION IN PART OR AS A WHOLE WITHOUT THE WRITTEN PERMISSION OF MITTLER BROS. MACHINE & TOOL IS PROHIBITED.

QUANTITY

MATERIAL

FINISH

**DO NOT SCALE DRAWING**

NAME DATE

DRAWN MSA 9/27/19

**UNLESS OTHERWISE SPECIFIED:**

DIMENSIONS ARE IN INCHES  
TOLERANCES:  
FRACTIONAL ±1/32  
ONE PLACE DECIMAL ±.015  
TWO PLACE DECIMAL ±.010  
THREE PLACE DECIMAL ±.005  
ANGULAR ±1°

COMMENTS:

**MITTLER BROS.  
MACHINE & TOOL**

10 Cooperative Way, Wright City, MO. 63390  
(636)745-7757 Fax (636)745-2874

TITLE:  
**MB Vise Assemblies**

SIZE DWG. NO. REV  
**B** 1100-A00

SCALE: 1:5 SHEET 1 OF 1